

ARCHITECTURAL GRILLE

Grille Type	Solar-Line
Material	Extruded Aluminum (Alloy 6063-T5)
Thickness	0.081 to 0.250 in. (2.06 to 6.35 mm)
Grille Depth	2 to 6 in. (50.8 to 152.4 mm)
Perimeter Frame	Aluminum Bar, Channel or Tube
Horizontal Bar Angle	0 to 45°
Horizontal Bar Spacing	2 to 12 in. (50.8 to 304.8 mm)
Vertical Bar Spacing	2 to 12 in. (50.8 to 304.8 mm)

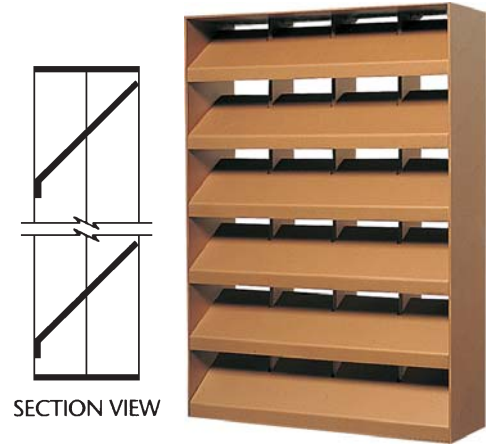

RECOMMENDED SPECIFICATION

Airolite Solar-Line Grilles are designed and produced to your custom specification to function as architectural accent elements or entire facades that yield sight and solar screening or serve as security barriers. Solar-Line Grilles feature a rear-justified vertical element that presents a unique grille profile dominated by its horizontal elements. In addition, the horizontal element incorporates a vertical leg on the leading-edge to lend rigidity and a sight or solar barrier. Solar-Line Grilles are produced in configurations from 2" (50.88 mm) to 6" (152.4 mm) deep and with extruded aluminum members that range in thickness from 0.081" (2.06 mm) to 0.250" (6.35 mm). The horizontal bar angle may vary from zero to 45-degrees to permit managed levels of sight or solar screening. Horizontal and vertical bar members can be configured from minimum 2" (50.8 mm) to maximum 12" (304.8 mm) center spacing to achieve desired sightlines. All materials are available in Airolite's broad array of baked enamel, fluoropolymer and clear or color anodize coatings for durability and compatibility with adjacent components. Please contact your local Airolite representative or the factory for assistance with the layout and design of support systems when required.

GENERAL

Where indicated on plan drawings or described in schedules, furnish and install Solar-Line Grilles as designed and manufactured by The Airolite Company LLC, Schofield, Wisconsin. Grilles shall be furnished in the configurations represented on the plan drawings and shall include supports, installation hardware and finishes as specified and required for a complete installation.

SUBMITTALS

Manufacturer shall submit shop drawings incorporating key plans, elevations, sections and details showing profiles, angles and spacing of components and frames; unit dimensions related to wall openings and construction; and, anchorage details and locations. Submit theoretical calculations prepared by a professional engineer specializing in the application of welding technology demonstrating that each fillet weld joining blade and frame members will withstand a minimum of 526 pounds of force in shear. Provide samples of manufacturer's finish and color charts showing the full range of finishes and colors available.

PRODUCTS

Architectural grilles shall be Airolite Solar-Line Grilles as follows:

- Material: Extruded Aluminum, Alloy 6063-T5
- Material Thickness: Specify 0.081" (2.06 mm) to 0.250" (6.35 mm), or as indicated.
- Grille Depth: Specify 2" (50.8 mm) to 6" (152.4 mm), or as indicated.
- Perimeter Frame: Specify Aluminum Bar, Channel or Tube, or as indicated.
- Horizontal Bar Angle: Specify zero to 45-degrees, or as indicated.
- Horizontal Bar Spacing: Specify 2" (50.8 mm) to 12" (304.8 mm), or as indicated.
- Vertical Bar Spacing: Specify 2" (50.8 mm) to 12" (304.8 mm), or as indicated.

ALL-WELDED ASSEMBLY

All horizontal, vertical and perimeter frame members shall be joined with slotted or tabbed connections. Where possible, connections shall be secured with fillet welds concealed from view, unless the size of the grille makes bolted connections between grille sections necessary. Each weld shall be a produced with the Pulsed Gas Metal Arc Welding (GMAW Mig) process. Intermediate connections shall be intermittently joined with a 1-inch (25.4 mm) long fillet weld with a minimum 1/8-inch (3.175 mm) leg. Frames shall be joined at each corner with a full-length GMAW fillet weld with a minimum 1/8-inch (3.175 mm) throat.

STRUCTURAL DESIGN CRITERIA

Manufacturer shall design and furnished all supports required to withstand a wind force of not less than 25 pounds per square foot. Grilles 120-inches (3,048 mm) wide x 120-inches (3,048 mm) high will be fabricated and installed in multiples sections (one dimension cannot exceed 72-inches). Grille members, frames, mullions and anchorages shall be demonstrated to withstand the specified wind design load.

See page 2 for complete finish options

GRILLE TYPE SOLAR-LINE DETAILS & FINISH OPTIONS

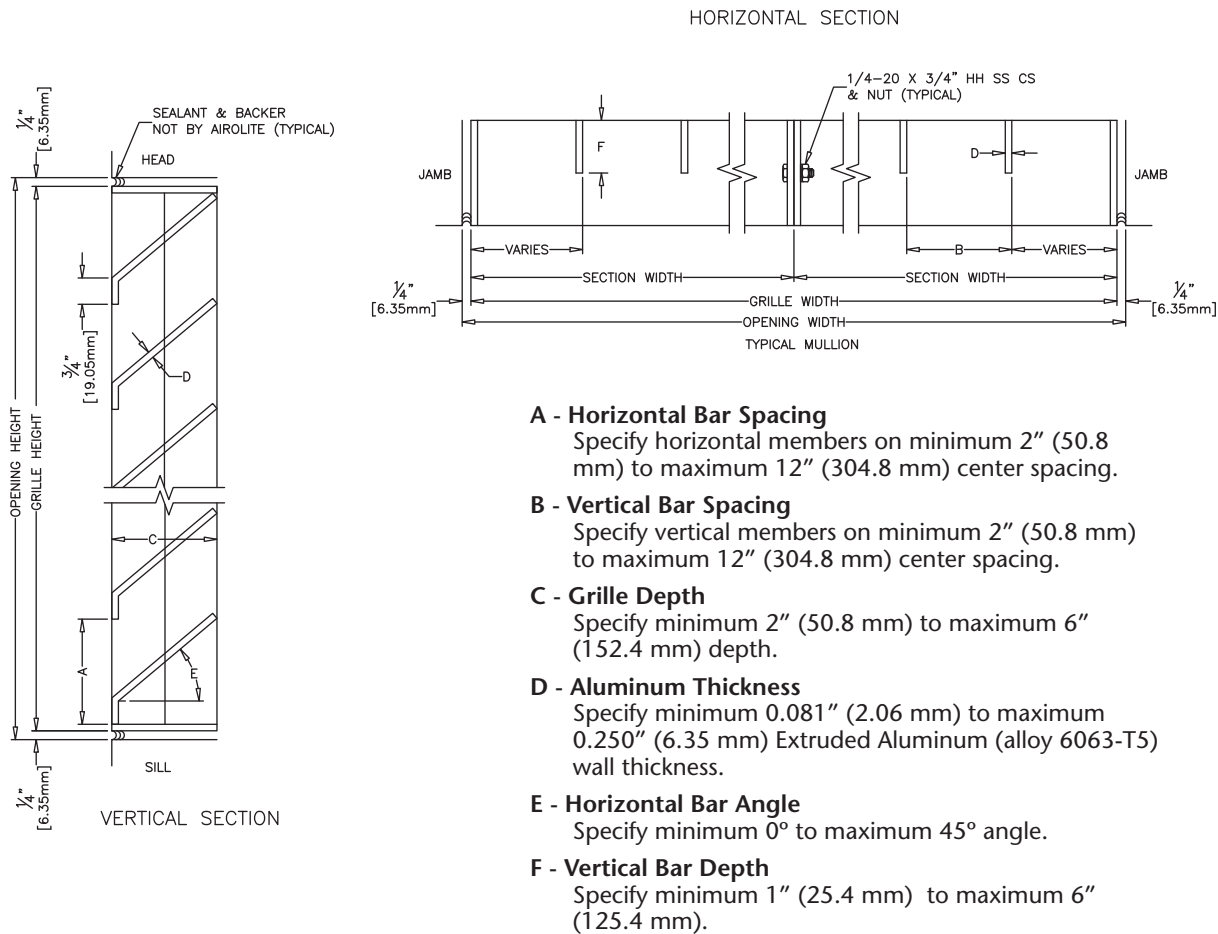

- A - Horizontal Bar Spacing**
Specify horizontal members on minimum 2" (50.8 mm) to maximum 12" (304.8 mm) center spacing.
- B - Vertical Bar Spacing**
Specify vertical members on minimum 2" (50.8 mm) to maximum 12" (304.8 mm) center spacing.
- C - Grille Depth**
Specify minimum 2" (50.8 mm) to maximum 6" (152.4 mm) depth.
- D - Aluminum Thickness**
Specify minimum 0.081" (2.06 mm) to maximum 0.250" (6.35 mm) Extruded Aluminum (alloy 6063-T5) wall thickness.
- E - Horizontal Bar Angle**
Specify minimum 0° to maximum 45° angle.
- F - Vertical Bar Depth**
Specify minimum 1" (25.4 mm) to maximum 6" (125.4 mm).

FINISHES (Select one of the following)

ACRYLIC ENAMEL: Louvers shall be cleaned, pretreated and FINISHED-AFTER-ASSEMBLY with an oven-cured thermosetting acrylic enamel finish that meets or exceeds the performance requirements of AAMA 2603, "Voluntary Specification Performance Requirements and Test Procedures for Pigmented Organic Coatings."

2-COAT FLUOROPOLYMER: Louvers shall be cleaned, pretreated and FINISHED-AFTER-ASSEMBLY with an inhibitive primer and oven-cured Kynar 500® / Hylar 5000® resin coating with minimum 1.2 mils dry-film coating thickness that meets or exceeds the performance requirements of AAMA 2605, "Voluntary Specification, Performance Requirements and Test Procedures for Superior Performance Organic Coatings on Aluminum Extrusions and Panels."

3-COAT FLUOROPOLYMER: Louvers shall be cleaned, pretreated and FINISHED-AFTER-ASSEMBLY with an inhibitive primer and oven-cured Kynar 500® / Hylar 5000® resin coating with minimum 2.0 mils dry-film coating thickness that meets or exceeds the performance requirements of AAMA 2605, "Voluntary Specification, Performance Requirements and Test Procedures for Superior Performance Organic Coatings on Aluminum Extrusions and Panels."

CLEAR ANODIZE: Louvers shall be FINISHED-AFTER-ASSEMBLY with a Class I clear anodized coating (AA-M10C22A41) that complies with the performance requirements of AAMA Specification 611-98, "Voluntary Specification for Anodized Architectural Aluminum."

COLOR ANODIZE: Louvers shall be FINISHED-AFTER-ASSEMBLY with a Class I electrolytically color anodized coating (AA-M10C22A42/44) that complies with the performance requirements of AAMA Specification 611-98, "Voluntary Specification for Anodized Architectural Aluminum." Color shall be (select one): Champagne, Light Bronze, Medium Bronze, Dark Bronze, Extra Dark Bronze or Black Anodize.



P.O. Box 410, 525 Western Road, Schofield, WI 54476-0410 USA
715.841.8757 • fax 715.841.8773 • www.airolite.com

Submission Solar-Line July 2006, Revision 4
Copyright ©2006 The Airolite Company, LLC

The Airolite Company, LLC reserves the right to make product changes.

THE ALL-WELDED ADVANTAGE