

VERTICAL SECTION

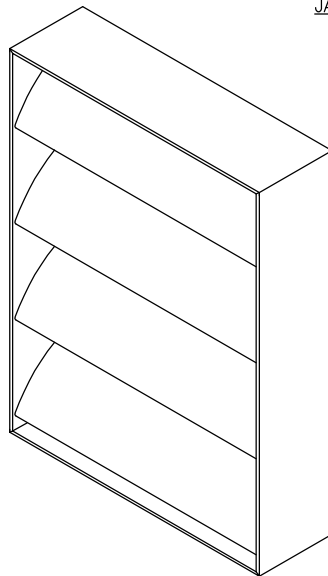

ISOMETRIC

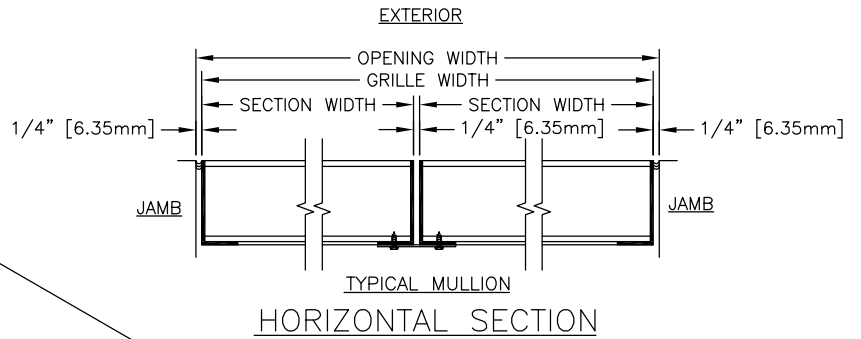

HORIZONTAL SECTION

SECTION SIZE LIMITS

	MINIMUM	MAXIMUM
WIDTH	10" (254MM)	144" * (3657.6MM)
HEIGHT	6" (152.4MM)	144" * (3657.6MM)

* ONE DIMENSION WIDTH OR HEIGHT MUST NOT EXCEED 60" (1524mm).

SPECIFY REQUIREMENTS IN SCHEDULE BELOW:					GRILLE FINISH	SCREEN	INSTALLATION METHOD
<p>A - AIRFOIL BLADE SPACING MINIMUM 2" (50.8mm) TO MAXIMUM 12" (304.8mm) TO</p> <p>B - GRILLE DEPTH: SPECIFY MINIMUM 3 1/2"(88.9mm) TO MAXIMUM 6"(152.4mm) DEPTH</p> <p>C - HORIZONTAL BLADE ANGLE: SPECIFY MINIMUM 0° TO MAXIMUM 60° ANGLE</p>					<input type="checkbox"/> NATURAL MILL <input type="checkbox"/> PRIME COAT	<input type="checkbox"/> NONE <input type="checkbox"/> INTERIOR	<input type="checkbox"/> CLIP ANGLES <input type="checkbox"/> HOLES IN PERIMETER <input type="checkbox"/> NONE <input type="checkbox"/> OTHER
					<input type="checkbox"/> BAKED ENAMEL <input type="checkbox"/> KYNAR 500 (2 COAT) <input type="checkbox"/> KYNAR 500 (3 COAT) SPECIFY COLOR SELECTION:	MESH	INSTALLATION FINISH
					ANODIZE <input type="checkbox"/> 215-R1 CLEAR ANODIZE <input type="checkbox"/> LIGHT BRONZE <input type="checkbox"/> MEDIUM BRONZE <input type="checkbox"/> DARK BRONZE <input type="checkbox"/> BLACK	<input type="checkbox"/> INSECT <input type="checkbox"/> 1/2"(12.7MM)MESH BIRD <input type="checkbox"/> _____	<input type="checkbox"/> NATURAL <input type="checkbox"/> _____
					<input type="checkbox"/> STAINLESS STEEL <input type="checkbox"/> ALUMINUM <input type="checkbox"/> _____	SCREEN MATERIAL	CONSTRUCTION METHOD
					<input type="checkbox"/> NATURAL <input type="checkbox"/> _____	SCREEN FINISH	ALL-WELDED ASSEMBLY 

ITEM	QTY.	A	B	C	OPENING SIZE		GRILLE SIZE		SECT QTY.	SECTION SIZE	
					WIDTH	HEIGHT	WIDTH	HEIGHT		WIDTH	HEIGHT



This drawing and the design represented are the confidential and proprietary property of THE AIROLITE COMPANY and may not be disclosed, loaned, copied or used for any purpose other than design review and approval without the expressed written consent of THE AIROLITE COMPANY.

LOUVER TYPE **AIRFOIL GRILLE**

MATERIAL: EXTRUDED ALUMINUM

DATE: 4-7-09

REV. NO:

FILE: STD AIRFOIL