

## ARCHITECTURAL GRILLE

<b>Grille Type</b>	Tetra
<b>Material</b>	Extruded Aluminum (Alloy 6063-T5)
<b>Horizontal Bar Thickness</b>	0.081 in. (2.06 mm)
<b>Vertical Bar Thickness</b>	0.125 in. (3.18 mm)
<b>Cross Member Thickness</b>	0.081 in. (2.06 mm)
<b>Frame Thickness</b>	0.125 in. (3.18 mm)
<b>Grille Depth</b>	2 or 4 in. (50.8 to 101.6 mm)
<b>Horizontal Bar Angle</b>	0 to 45°
<b>Horizontal Bar Spacing</b>	4 to 12 in. (101.6 to 304.8 mm)
<b>Vertical Bar Spacing</b>	4 to 12 in. (101.6 to 304.8 mm)

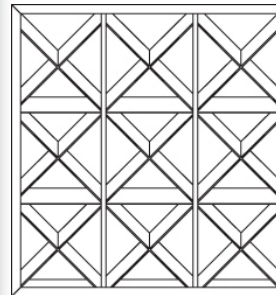

ELEVATION VIEW

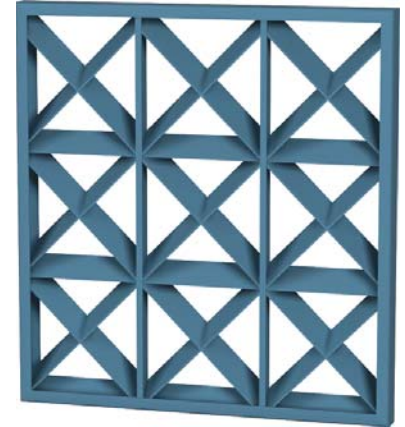

## RECOMMENDED SPECIFICATION

**Aiolite Tetra Grilles** are designed and produced to your custom specification to serve as architectural accent elements or entire facades that function as sight screens, sun controls or security barriers. Tetra Grilles are produced in 2-inch (50.8 mm) or 4-inch (101.6 mm) depths with horizontal and vertical elements that feature diagonal cross members. The grille configuration can be altered to achieve open or narrow sight-lines by modifying the horizontal and vertical member spacing. Minimum horizontal and vertical member spacing is 4-inches (101.6 mm); and, maximum spacing is 12-inches (304.8 mm). In addition, the horizontal bar can be rotated from 0 to 45-degrees to achieve maximum openness or serve as an effective sight or solar barrier. The rigidity of the assembly also makes the Tetra Grille ideal for many security applications. Tetra Grilles are available in Aiolite's broad array of baked enamel, fluoropolymer and clear or color anodize coatings for durability and compatibility with adjacent components. Please contact your local Aiolite representative or the factory for assistance with the layout and design of support systems when required.

### GENERAL

Where indicated on plan drawings or described in schedules, furnish and install Tetra Grilles as designed and manufactured by The Aiolite Company LLC, Schofield, Wisconsin. Grilles shall be furnished in the configurations represented on the plan drawings and shall include supports, installation hardware and finishes as specified and required for a complete installation.

### SUBMITTALS

Manufacturer shall submit shop drawings incorporating key plans, elevations, sections and details showing profiles, angles and spacing of components and frames; unit dimensions related to wall openings and construction; and, anchorage details and locations. Submit theoretical calculations prepared by a professional engineer specializing in the application of welding technology demonstrating that each fillet weld joining horizontal, vertical and frame members shall withstand a minimum of 526 pounds of force in shear. Provide samples of manufacturer's finish and color charts showing the full range of finishes and colors available.

### PRODUCTS

Architectural grilles shall be Aiolite Tetra Grilles as follows:

- Material: Extruded Aluminum, Alloy 6063-T5
- Horizontal Bar Thickness: Specify 0.081" (2.06 mm), or as indicated.
- Vertical Bar Thickness: Specify 0.125" (3.18 mm), or as indicated.
- Cross Member Thickness: Specify 0.081" (2.06 mm), or as indicated.
- Frame Thickness: Specify 0.125" (3.18 mm), or as indicated.
- Grille Depth: Specify 2" (50.8 mm) to 4" (101.6 mm), or as indicated.
- Horizontal Bar Angle: Specify 0 to 45°, or as indicated.
- Horizontal Bar Spacing: Specify 4" (101.6 mm) to 12" (304.8 mm), or as indicated.
- Vertical Bar Spacing: Specify 4" (101.6 mm) to 12" (304.8 mm), or as indicated.

### ALL-WELDED ASSEMBLY

All horizontal, vertical and perimeter frame members shall be joined with slotted or tabbed connections. Where possible, connections shall be secured with fillet welds concealed from view; unless the size of the grille makes bolted connections between grille sections necessary. Each weld shall be produced with the Pulsed Gas Metal Arc Welding (GMAW Mig) process. Intermediate connections shall be intermittently joined with a 1-inch (25.4 mm) long fillet weld with a minimum 1/8-inch (3.175 mm) leg. Frames shall be joined at each corner with a full-length GMAW fillet weld with a minimum 1/8-inch (3.175 mm) throat.

### STRUCTURAL DESIGN CRITERIA

Manufacturer shall design and furnish all supports required to withstand a wind force of not less than 25 pounds per square foot. Grilles larger than 72-inches wide (1,828.8 mm) x 120-inches high (3,048 mm) or 120-inches (3,048 mm) wide x 72-inches (1,828.8 mm) high will be fabricated and installed in multiple sections. Grille members, frames, mullions and anchorages will be demonstrated to withstand the specified wind design load.

See page 2 for complete finish options

# GRILLE TYPE TETRA DETAILS & FINISH OPTIONS

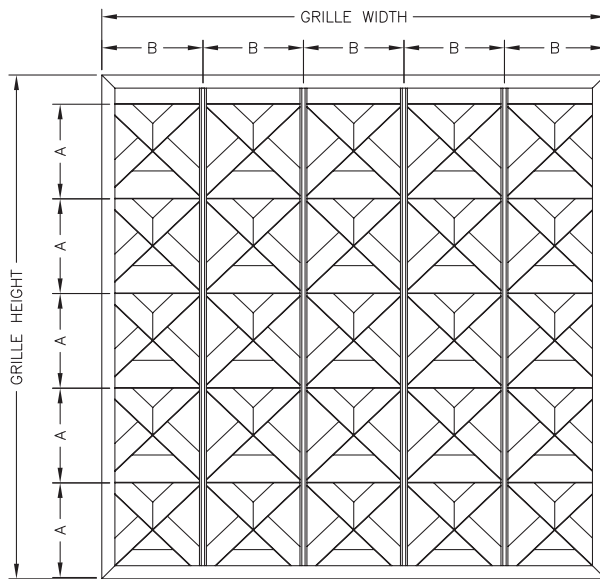

## A - Horizontal Bar Spacing

Specify horizontal members on minimum 4" (101.6 mm) to maximum 12" (304.8 mm) center spacing.

## B - Vertical Bar Spacing

Specify vertical members on minimum 4" (101.6 mm) to maximum 12" (304.8 mm) center spacing.

## C - Grille Depth

Specify minimum 2" (50.8 mm) or maximum 4" (101.6 mm) depth.

## D - Horizontal & Cross Bar Depth

Size is determined when other variables have been specified.

## E - Aluminum Thickness

Specify minimum 0.081" (2.06 mm) horizontal bar thickness Extruded Aluminum (alloy 6063-T5) and 0.125" (3.18 mm) vertical bar thickness Extruded Aluminum (alloy 6063-T5) wall thickness.

## F - Horizontal Bar Angle

Specify minimum of 0° to maximum of 45°.

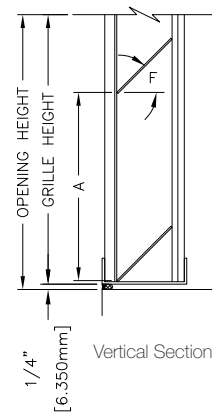
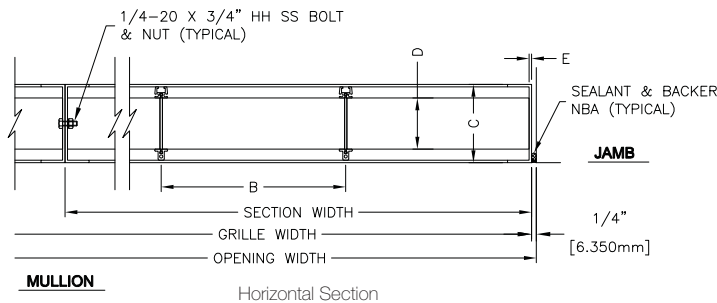

## FINISHES (Select one of the following)

**ACRYLIC ENAMEL:** Louvers shall be cleaned, pretreated and FINISHED-AFTER-ASSEMBLY with an oven-cured thermosetting acrylic enamel finish that meets or exceeds the performance requirements of AAMA 2603, "Voluntary Specification Performance Requirements and Test Procedures for Pigmented Organic Coatings."

**2-COAT FLUOROPOLYMER:** Louvers shall be cleaned, pretreated and FINISHED-AFTER-ASSEMBLY with an inhibitive primer and oven-cured Kynar 500® / Hylar 5000® resin coating with minimum 1.2 mils dry-film coating thickness that meets or exceeds the performance requirements of AAMA 2605, "Voluntary Specification, Performance Requirements and Test Procedures for Superior Performance Organic Coatings on Aluminum Extrusions and Panels."

**3-COAT FLUOROPOLYMER:** Louvers shall be cleaned, pretreated and FINISHED-AFTER-ASSEMBLY with an inhibitive primer and oven-cured Kynar 500® / Hylar 5000® resin coating with minimum 2.0 mils dry-film coating thickness that meets or exceeds the performance requirements of AAMA 2605, "Voluntary Specification, Performance Requirements and Test Procedures for Superior Performance Organic Coatings on Aluminum Extrusions and Panels."

**CLEAR ANODIZE:** Louvers shall be FINISHED-AFTER-ASSEMBLY with a Class I clear anodized coating (AA-M10C22A41) that complies with the performance requirements of AAMA Specification 611-98, "Voluntary Specification for Anodized Architectural Aluminum."

**COLOR ANODIZE:** Louvers shall be FINISHED-AFTER-ASSEMBLY with a Class I electrolytically color anodized coating (AA-M10C22A42/44) that complies with the performance requirements of AAMA Specification 611-98, "Voluntary Specification for Anodized Architectural Aluminum." Color shall be (select one): Champagne, Light Bronze, Medium Bronze, Dark Bronze, Extra Dark Bronze or Black Anodize.



P.O. Box 410, 525 Western Road, Schofield, WI 54476-0410 USA  
715.841.8757 • fax 715.841.8773 • www.airolite.com

Submission Tetra January 2008, Revision 1  
Copyright ©2008 The Airolite Company, LLC

The Airolite Company, LLC reserves the right to make product changes.

**THE ALL-WELDED ADVANTAGE**