

 AIROLITE The look that works.™	MODEL: T9212
	SHEET: 1 OF 2

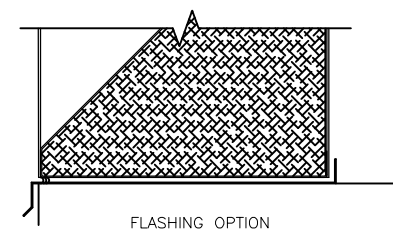
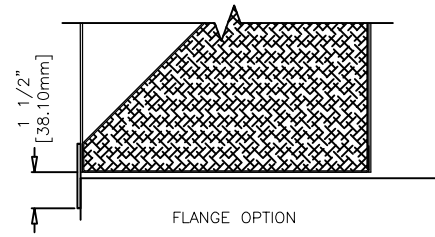
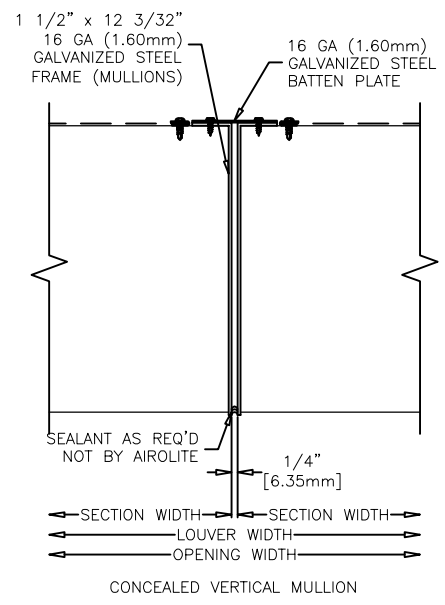
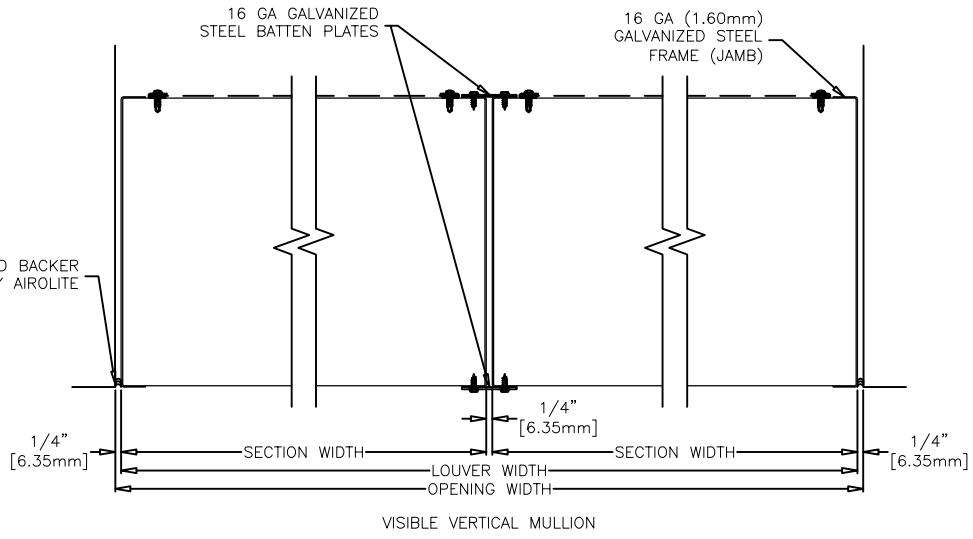
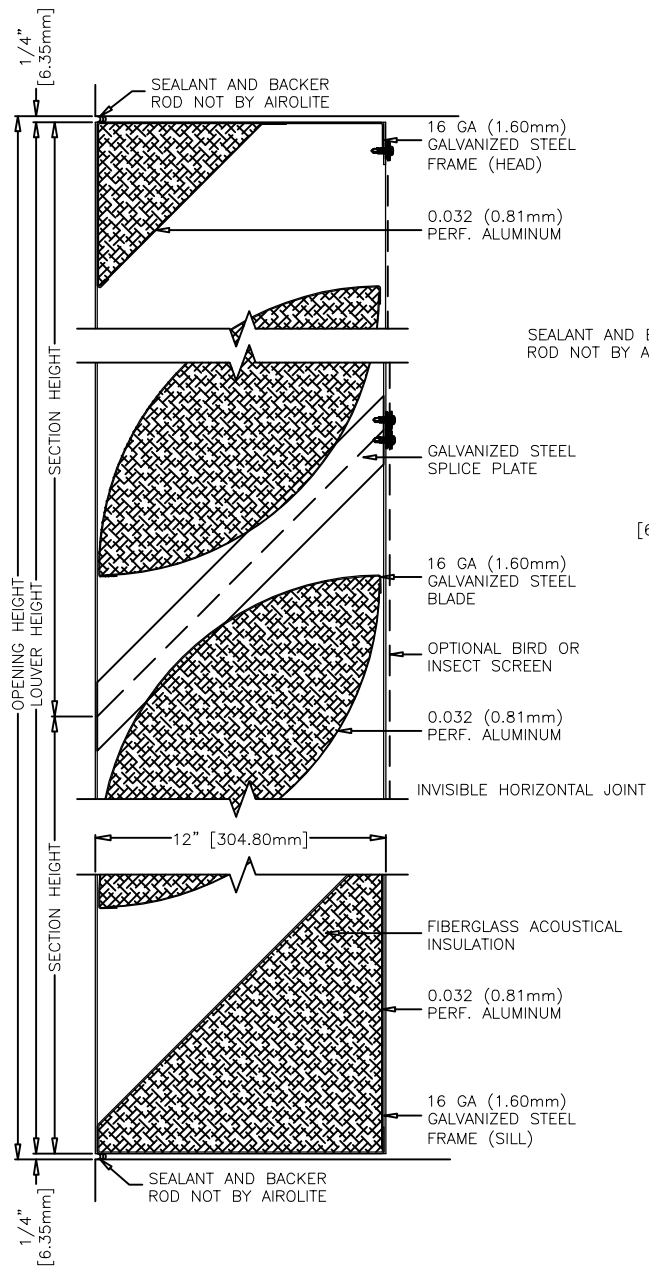

AIROLITE
 The look that works.SM

MODEL: 9212
SHEET: 2 OF 2