

1/4-20 x 2.5 HWH BOLT & NUT
FIELD DRILL & INSTALL 1 @ HEAD.

#10 x 1 HWH SS TEK
ALTERNATE DIRECTION 16" O.C.
FIELD DRILLED AND INSTALLED

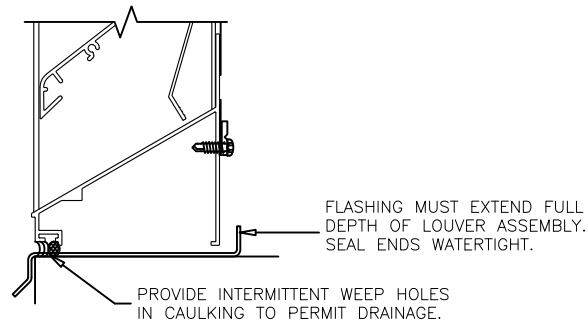

FLASHING OPTION

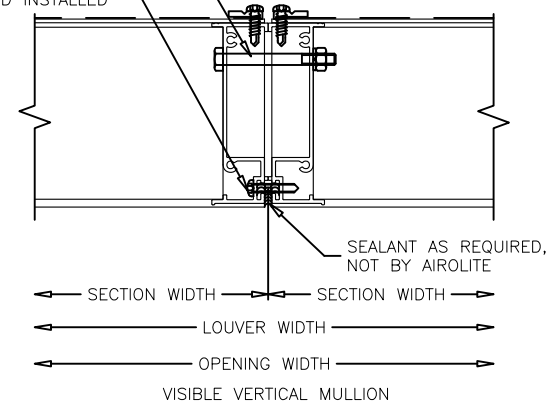
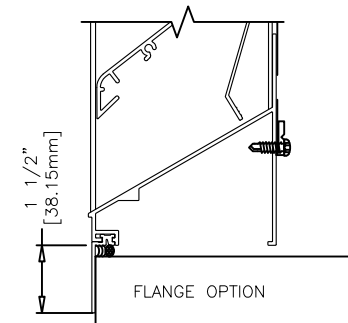

This drawing and the design represented are the confidential and proprietary property of THE AIROLITE COMPANY and may not be disclosed, loaned, copied or used for any purpose other than design review and approval without the expressed written consent of THE AIROLITE COMPANY.

SCALE: NTS

DATE: 4/1/10

REV. NO: ---

FILE: KX827

LOUVER TYPE

KX827

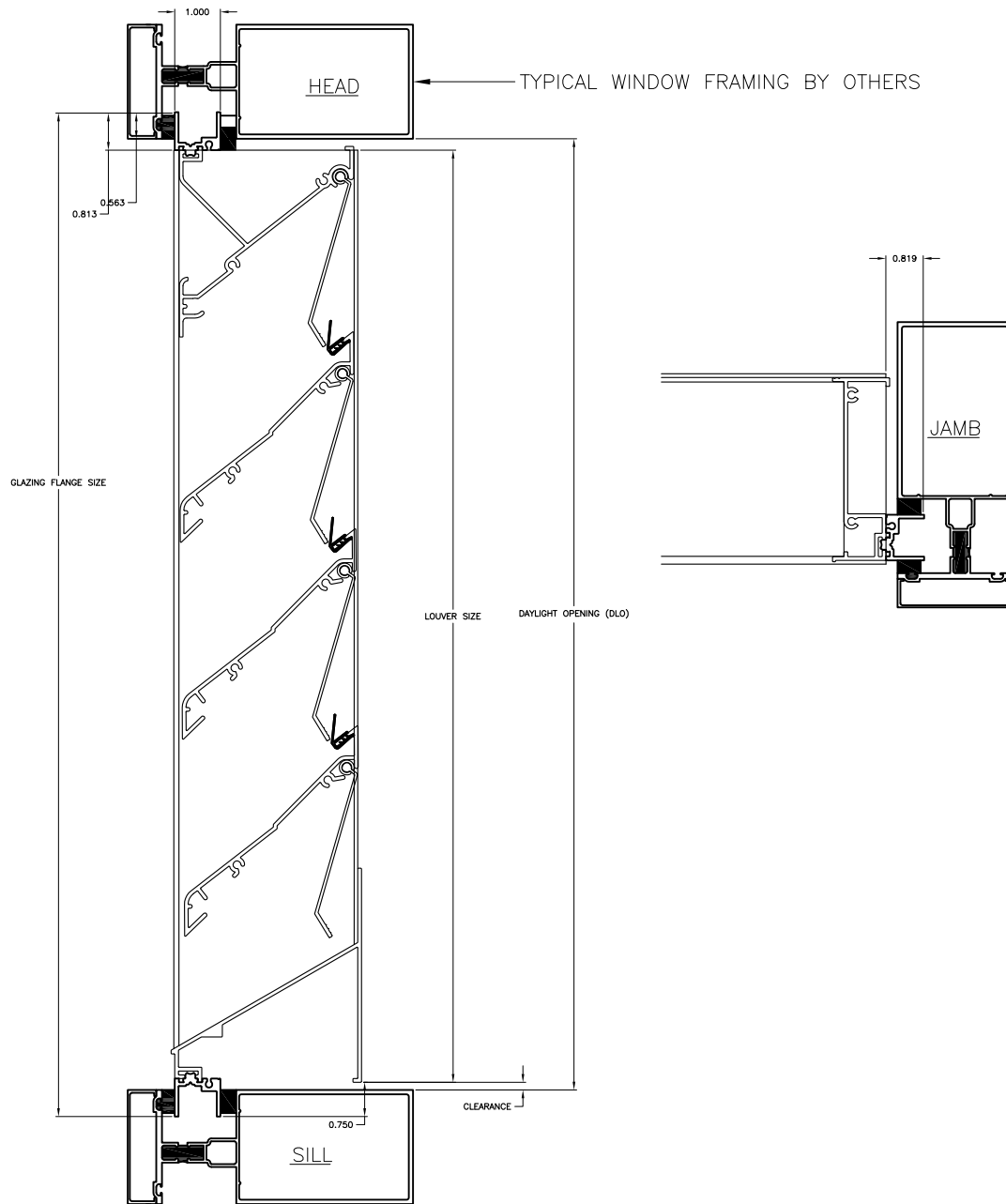

This drawing and the design represented are the confidential and proprietary property of THE AIROLITE COMPANY and may not be disclosed, loaned, copied or used for any purpose other than design review and approval without the expressed written consent of THE AIROLITE COMPANY.

SCALE: NTS

DATE: 4/1/10

REV. NO: ---

FILE: KX827

LOUVER TYPE

KX827