

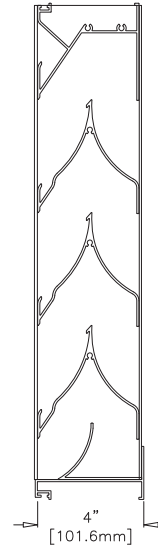

SIGHTPROOF LOUVER

| | |
|--|---------------------------------------|
| Visible Mullion Louver Type | K601D |
| Concealed Mullion Louver Type | CB601D |
| Material | Extruded Aluminum (Alloy 6063-T5) |
| Stationary Blade | 0.081 in. (2.06 mm) |
| Frame | 0.081 in. (2.06 mm) |
| Louver Depth | 4 in. (101.6 mm) |
| Free Area – 4 ft. x 4 ft. Unit | 5.16 sq. ft. (0.48 sq m) |
| Percent Free Area | 32.3% |
| Free Area Velocity at Beginning Point of Water Penetration – 0.01 oz H₂O/sq. ft. Free Area | 747 fpm (3.79 m/s) |
| Air Volume Flow Rate at Beginning Point of Water Penetration – 4 ft. x 4 ft. Unit | 3,855 cfm (1.82 m ³ /s) |
| Pressure Drop at Beginning Point of Water Penetration | 0.30 in. H ₂ O (0.075 kPa) |



RECOMMENDED SPECIFICATION

GENERAL

Furnish and install where indicated on plans or described in schedules Airlite Louver Type K601D (or CB601D) as designed and manufactured by The Airlite Company LLC, Schofield, Wisconsin. Louvers shall be furnished with bird screen, insect screen, supports, installation hardware and finishes as specified and as required for a complete installation.

SUBMITTALS

Manufacturer shall submit shop drawings incorporating key plans, elevations, sections and details showing profiles, angles and spacing of louver blades and frames; unit dimensions related to wall openings and construction; and, anchorage details and locations. Provide samples of manufacturer's finish and color charts showing the full range of colors available. For each type of product specified, submit free area, air performance and water penetration ratings determined in accordance with AMCA Standard 500-L and licensed under the AMCA Certified Ratings Program.

PRODUCTS

Louvers shall be sightproof Louver Type K601D with visible vertical mullions (or Louver Type CB601D with concealed vertical mullions). Louvers shall be 4-inches (101.6 mm) deep and assembled entirely from extruded aluminum components. Blades and frames shall be 0.081-inch (2 mm) thick aluminum, alloy 6063-T5. Blades shall be horizontal, inverted-V type with a center hook, incorporate drainable gutters and be spaced 4.25-inches (108.0 mm) on center.

STRUCTURAL DESIGN CRITERIA

Manufacturer shall design and furnish all supports required to withstand a wind force of not less than 25 pounds per square foot. Louvers larger than 84-inches wide x 120-inches high or 120-inches wide x 84-inches high will be fabricated and installed in multiple sections. Louver blades, frames, mullions and anchorages shall be demonstrated to withstand the specified wind design load.

PERFORMANCE RATINGS

| | |
|--|---|
| FREE AREA: | 5.16 Square Feet (0.48 m ²) |
| MINIMUM FREE AREA VELOCITY at Beginning Point of Water Penetration: | 747 fpm (3.79 m/s) |
| MINIMUM AIR VOLUME FLOW RATE at Beginning Point of Water Penetration: | 3,855 cfm (1.82 m ³ /s) |
| MAXIMUM STATIC PRESSURE at Beginning Point of Water Penetration: | 0.30 in. H ₂ O (0.075 kPa) |

See page 4 for complete finish options

LOUVER TYPE K601D PRODUCT DESCRIPTION & DETAILS

AIROLITE LOUVER TYPE K601D is a 4-inch deep, extruded aluminum, sightproof and drainable louver suitable for louver installations at grade or wherever security and resistance to intrusion are primary concerns. The inverted V-blade is 100% sightproof when viewed from any orientation and poses a formidable barrier to intruding devices such as sticks and wires. Drainable louvers are characterized by gutters incorporated at the front-edge of each blade to prevent water droplets from cascading from blade-to-blade and becoming entrained in the intake air flow. Vertical gutters located in each jamb frame drain water to the sill frame where it exits from the louver assembly between the sill frame and bottom blade. Specify Louver Type K601D with visible vertical mullions; and, Louver Type CB611D with concealed vertical mullions. Louver Type K601D is an effective louver with AMCA Licensed air performance, and water penetration ratings that enable designers to select and specify this product with confidence. Please contact your local Airolite representative or the factory for assistance with the layout and design of support systems when required.

VERTICAL SECTION DETAIL

PLAN SECTION DETAIL

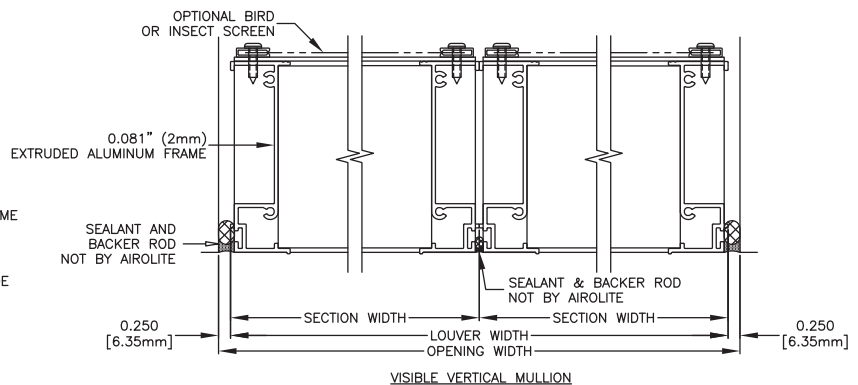
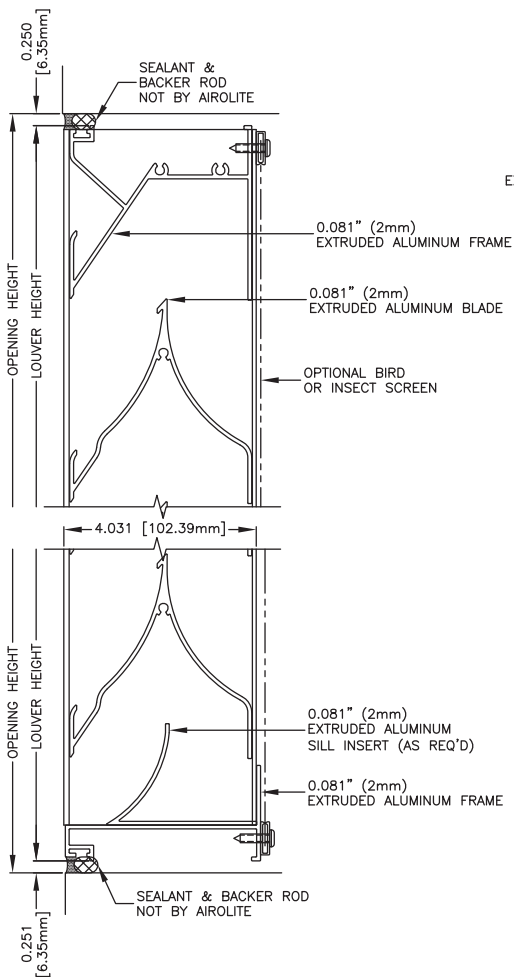

ACCESSORY ITEMS

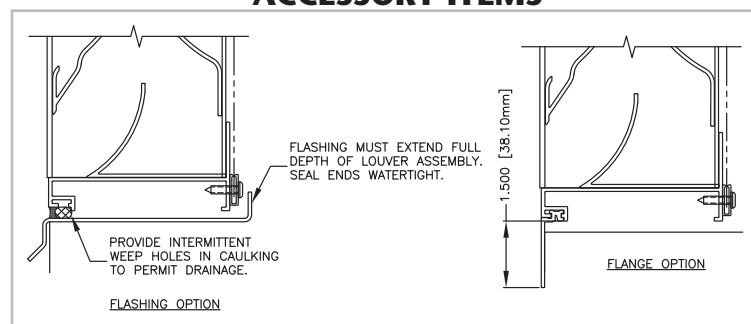

Minimum Section Size:

12 in. (30 cm) W x 12 in. (30 cm) H

Maximum Section Size:

120 in. (305 cm) W x 120 in. (305 cm) H
*one dimension cannot exceed 84 in.

LOUVER TYPE K601D PERFORMANCE RATINGS

FREE AREA CHART - in square feet

| Louver Height Inches | Louver Width in Inches | | | | | | | | | | | | |
|----------------------|------------------------|------|------|-------|-------|-------|-------|-------|-------|-------|-------|-------|-------|
| | 12 | 18 | 30 | 36 | 48 | 54 | 66 | 72 | 84 | 90 | 102 | 108 | 120 |
| 12 | 0.18 | 0.30 | 0.53 | 0.64 | 0.87 | 0.99 | 1.19 | 1.30 | 1.53 | 1.65 | 1.87 | 1.99 | 2.19 |
| 18 | 0.33 | 0.53 | 0.95 | 1.16 | 1.57 | 1.78 | 2.14 | 2.35 | 2.76 | 2.97 | 3.38 | 3.59 | 3.95 |
| 24 | 0.52 | 0.84 | 1.50 | 1.83 | 2.48 | 2.81 | 3.38 | 3.70 | 4.36 | 4.68 | 5.34 | 5.66 | 6.24 |
| 30 | 0.91 | 1.49 | 2.64 | 3.22 | 4.37 | 4.95 | 5.96 | 6.54 | 7.69 | 8.27 | 9.42 | 10.00 | 11.01 |
| 36 | 0.79 | 1.29 | 2.29 | 2.78 | 3.78 | 4.28 | 5.15 | 5.65 | 6.65 | 7.15 | 8.15 | 8.64 | 9.52 |
| 42 | 0.94 | 1.54 | 2.73 | 3.33 | 4.52 | 5.12 | 6.16 | 6.76 | 7.95 | 8.55 | 9.74 | 10.33 | 11.38 |
| 48 | 1.08 | 1.76 | 3.12 | 3.80 | 5.16 | 5.84 | 7.04 | 7.72 | 9.08 | 9.76 | 11.12 | 11.80 | 12.99 |
| 54 | 1.28 | 2.10 | 3.71 | 4.52 | 6.14 | 6.94 | 8.36 | 9.17 | 10.79 | 11.60 | 13.21 | 14.02 | 15.44 |
| 60 | 1.40 | 2.28 | 4.05 | 4.94 | 6.70 | 7.59 | 9.13 | 10.02 | 11.79 | 12.67 | 14.44 | 15.32 | 16.87 |
| 66 | 1.56 | 2.54 | 4.51 | 5.49 | 7.46 | 8.44 | 10.16 | 11.14 | 13.11 | 14.09 | 16.06 | 17.04 | 18.76 |
| 72 | 1.71 | 2.79 | 4.94 | 6.02 | 8.17 | 9.25 | 11.12 | 12.22 | 14.37 | 15.45 | 17.61 | 18.68 | 20.57 |
| 78 | 1.83 | 2.98 | 5.29 | 6.45 | 8.76 | 9.91 | 11.93 | 13.09 | 15.40 | 16.55 | 18.86 | 20.02 | 22.04 |
| 84 | 2.04 | 3.34 | 5.92 | 7.21 | 9.79 | 11.08 | 13.34 | 14.63 | 17.21 | 18.51 | 21.09 | 22.38 | 24.64 |
| 90 | 2.15 | 3.51 | 6.22 | 7.58 | 10.30 | 11.66 | 14.03 | 15.39 | 18.11 | 19.46 | 22.18 | 23.54 | 25.91 |
| 96 | 2.32 | 3.79 | 6.73 | 8.19 | 11.13 | 12.60 | 15.16 | 16.63 | 19.57 | 21.03 | 23.97 | 25.44 | 28.00 |
| 102 | 2.47 | 4.03 | 7.15 | 8.71 | 11.83 | 13.39 | 16.12 | 17.68 | 20.80 | 22.36 | 25.48 | 27.04 | 29.77 |
| 108 | 2.60 | 4.24 | 7.51 | 9.15 | 12.43 | 14.07 | 16.94 | 18.58 | 21.86 | 23.50 | 26.78 | 28.41 | 31.28 |
| 114 | 2.76 | 4.49 | 7.97 | 9.71 | 13.19 | 14.93 | 17.98 | 19.72 | 23.20 | 24.94 | 28.42 | 30.16 | 33.20 |
| 120 | 2.90 | 4.73 | 8.40 | 10.23 | 13.89 | 15.72 | 18.93 | 20.76 | 24.43 | 26.26 | 29.92 | 31.75 | 34.96 |



The Aiolite Company, LLC certifies that Louver Type K601D shown herein is licensed to bear the AMCA seal. The ratings shown are based on tests and procedures performed in accordance with AMCA Publication 511 and comply with the requirements of the AMCA Certified Ratings Program. The AMCA Certified Ratings Seal applies only to Air Performance and Water Penetration ratings.

AIRFLOW RESISTANCE

(Standard Air - .075 lb./ft.³)

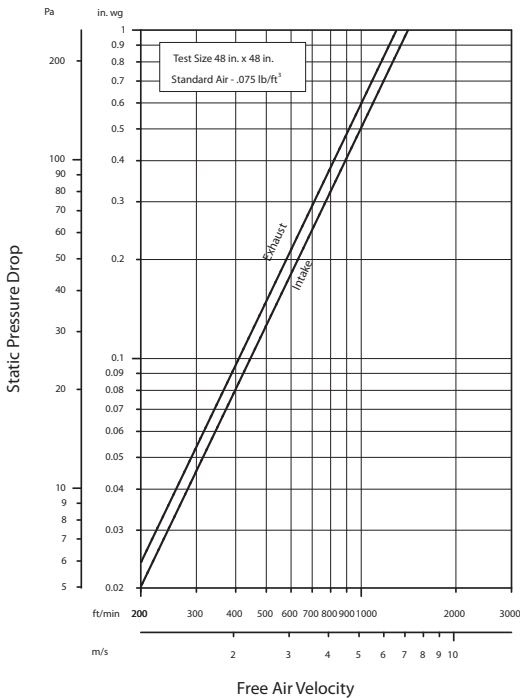

Louver Type K601D resistance to airflow is shown with louver blades fully open. Resistance (pressure drop) varies depending on louver application (air intake or air exhaust). Free area velocities (shown) are higher than average velocity through the overall louver size.

WATER PENETRATION

(Standard Air - .075 lb./ft.³)

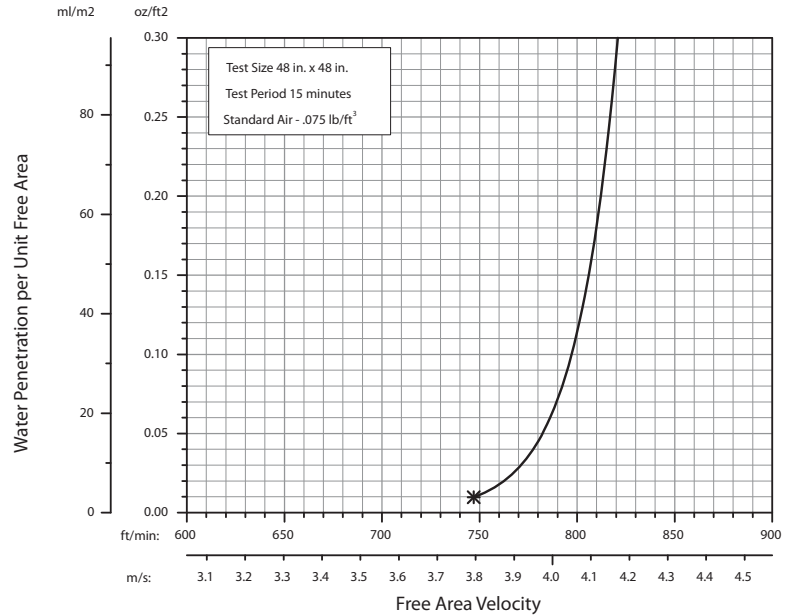

The AMCA Water Penetration Test provides a method for comparing various louver models and designs as to their efficiency in resisting the penetration of rainfall under specific laboratory test conditions. The point of zero water penetration is defined as that velocity where the water penetration curve projects through .01 oz. of water (penetration) per sq. ft. of louver free area. ***The beginning point of water penetration for Louver Type K601D is 747 fpm free area velocity.** These performance ratings do not guarantee a louver to be weatherproof or stormproof and should be used in combination with other factors including good engineering judgement in selecting louvers.

LOUVER TYPE K601D

METHOD OF INSTALLATION & ACCESSORY OPTIONS

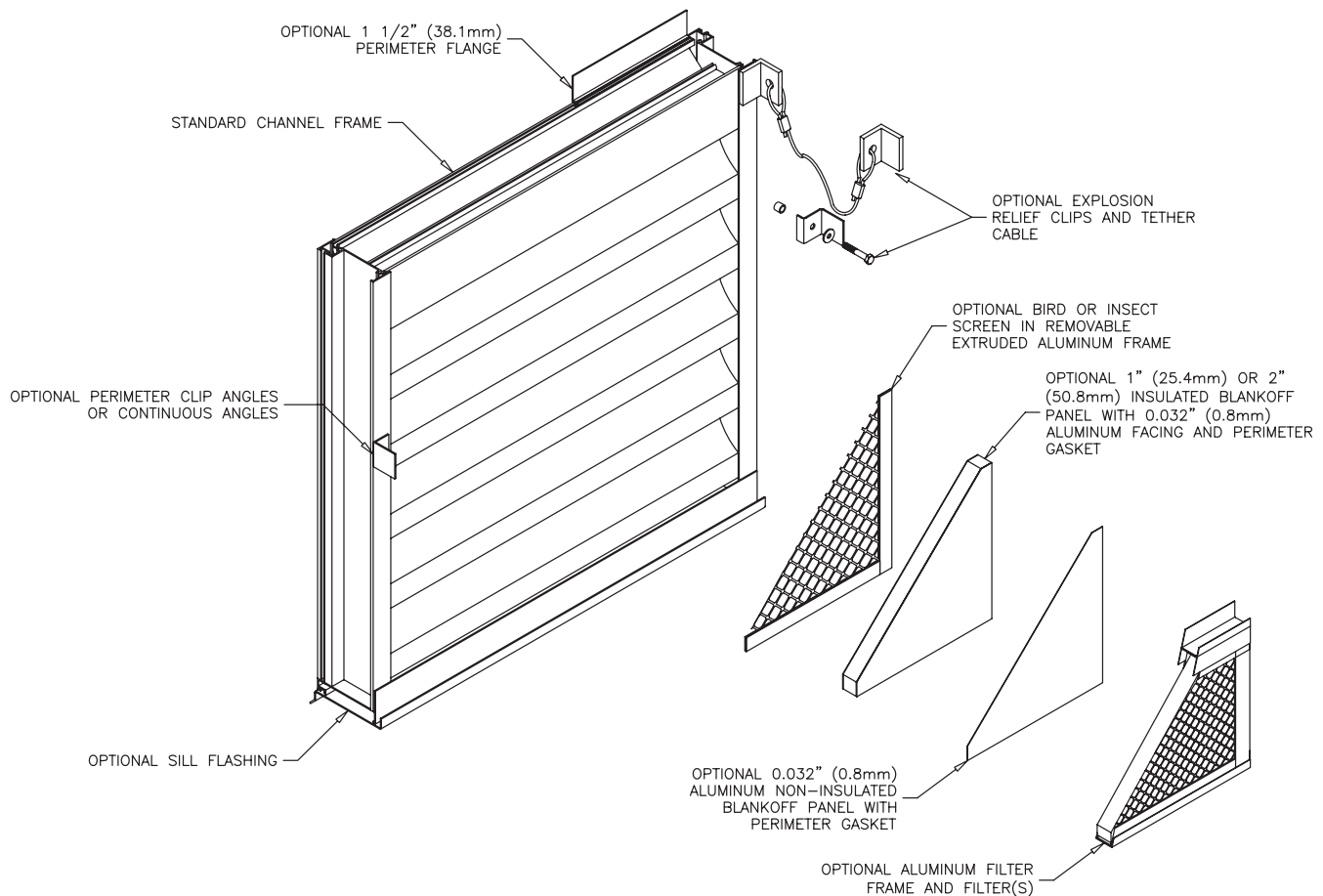

FINISHES (Select one of the following)

ACRYLIC ENAMEL: Louvers shall be cleaned, pretreated and Finished with an oven-cured thermosetting acrylic enamel finish that meets or exceeds the performance requirements of AAMA 2603, "Voluntary Specification Performance Requirements and Test Procedures for Pigmented Organic Coatings."

2-COAT FLUOROPOLYMER: Louvers shall be cleaned, pretreated and Finished with an inhibitive primer and oven-cured Kynar 500® / Hylar 5000® resin coating with minimum 1.2 mils dry-film coating thickness that meets or exceeds the performance requirements of AAMA 2605, "Voluntary Specification, Performance Requirements and Test Procedures for Superior Performance Organic Coatings on Aluminum Extrusions and Panels."

3-COAT FLUOROPOLYMER: Louvers shall be cleaned, pretreated and Finished with an inhibitive primer and oven-cured Kynar 500® / Hylar 5000® resin coating with minimum 2.0 mils dry-film coating thickness that meets or exceeds the performance requirements of AAMA 2605, "Voluntary Specification, Performance Requirements and Test Procedures for Superior Performance Organic Coatings on Aluminum Extrusions and Panels."

CLEAR ANODIZE: Louvers shall be Finished with a Class I clear anodized coating (AA-M10C22A41) that complies with the performance requirements of AAMA Specification 611-98, "Voluntary Specification for Anodized Architectural Aluminum."

COLOR ANODIZE: Louvers shall be Finished with a Class I electrolytically color anodized coating (AA-M10C22A42/44) that complies with the performance requirements of AAMA Specification 611-98, "Voluntary Specification for Anodized Architectural Aluminum." Color shall be (select one): Champagne, Light Bronze, Medium Bronze, Dark Bronze, Extra Dark Bronze or Black Anodize.



P.O. Box 410, 525 Western Road, Schofield, WI 54476-0410 USA
715.841.8757 • fax 715.841.8773 • www.airolite.com

Submittal K601D June 2006, Revision 1
Copyright ©2006 The Airolite Company, LLC

The Airolite Company, LLC reserves the right to make product changes.