

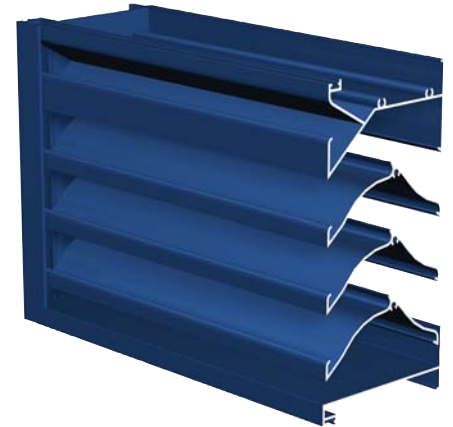

## SIGHTPROOF DRAINABLE LOUVER

<b>Visible Mullion Louver Type</b> .....	K605D
<b>Concealed Mullion Louver Type</b> .....	CB605D
<b>Material</b> .....	Extruded Aluminum (Alloy 6063-T5)
<b>Stationary Blade</b> .....	0.081 in. (2.06 mm)
<b>Frame</b> .....	0.081 in. (2.06 mm)
<b>Louver Depth</b> .....	5 in. (127.0 mm)
<b>Free Area – 4 ft. x 4 ft. Unit</b> .....	9.11 sq. ft. (0.85 sq m)
<b>Percent Free Area</b> .....	56.9%
<b>Free Area Velocity at Beginning Point of Water Penetration – 0.01 oz H<sub>2</sub>O/sq. ft. Free Area</b> .....	
1,134 fpm (5.76 m/s)	
<b>Air Volume Flow Rate at Beginning Point of Water Penetration – 4 ft. x 4 ft. Unit</b> .....	
10,331 cfm (4.896 m <sup>3</sup> /s)	
<b>Pressure Drop at Beginning Point of Water Penetration</b> .....	
0.40 in. H <sub>2</sub> O (0.100 kPa)	

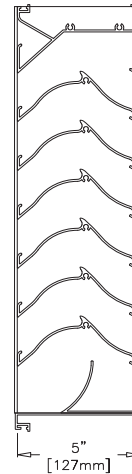

### RECOMMENDED SPECIFICATION

#### GENERAL

Furnish and install where indicated on plans or described in schedules Aiolrite Louver Type K605D as designed and manufactured by The Aiolrite Company LLC, Schofield, Wisconsin. Louvers shall be furnished with bird screen, insect screen, supports, installation hardware and finishes as specified and as required for a complete installation.

#### SUBMITTALS

Manufacturer shall submit shop drawings incorporating key plans, elevations, sections and details showing profiles, angles and spacing of louver blades and frames; unit dimensions related to wall openings and construction; and, anchorage details and locations. Provide samples of manufacturer's finish and color charts showing the full range of colors available. For each type of product specified, submit free area, air performance and water penetration ratings determined in accordance with AMCA Standard 500-L and licensed under the AMCA Certified Ratings Program.

#### PRODUCTS

Louvers shall be sightproof and drainable Louver Type K605D. Louvers shall be 5-inches (127 mm) deep and assembled entirely from extruded aluminum components. Blades and frames shall be 0.081-inch (2 mm) thick aluminum, alloy 6063-T5. Blades shall be horizontal, inverted-V type with a center hook and spaced 2-inches (50.8 mm) on center.

#### STRUCTURAL DESIGN CRITERIA

Manufacturer shall design and furnish all supports required to withstand a wind force of not less than 25 pounds per square foot. Louvers larger than 84-inches wide x 120-inches high or 120-inches wide x 84-inches high will be fabricated and installed in multiple sections. Louver blades, frames, mullions and anchorages shall be demonstrated to withstand the specified wind design load.

#### PERFORMANCE RATINGS

FREE AREA:	9.11 Square Feet (0.85 m <sup>2</sup> )
MINIMUM FREE AREA VELOCITY at Beginning Point of Water Penetration:	1,134 fpm (5.76 m/s)
MINIMUM AIR VOLUME FLOW RATE at Beginning Point of Water Penetration:	10,331 cfm (4.896 m <sup>3</sup> /s)
MAXIMUM STATIC PRESSURE at Beginning Point of Water Penetration:	0.40 in. H <sub>2</sub> O (0.100 kPa)

See page 4 for complete finish options

# LOUVER TYPE K605D PRODUCT DESCRIPTION & DETAILS

**AIROLITE LOUVER TYPE K605D** is a 5-inch deep, extruded aluminum, sightproof and drainable louver this is suitable for a number of architectural applications. The 2-inch (50.4 mm) blade spacing and 100% sightproof blade configuration afford a narrow, well-defined symmetry, and uniform appearance with distinct shadow lines. In addition to its striking monumental appearance, Louver Type K605D yields high free area, high volume air volume flow rates, and moderate resistance to water penetration. Louver Type K605D is a highly effective louver with AMCA Licensed air performance, and water penetration ratings that enable designers to select and specify this product with confidence. Please contact your local Airlite representative or the factory for assistance with the layout and design of support systems when required.

## VERTICAL SECTION DETAIL

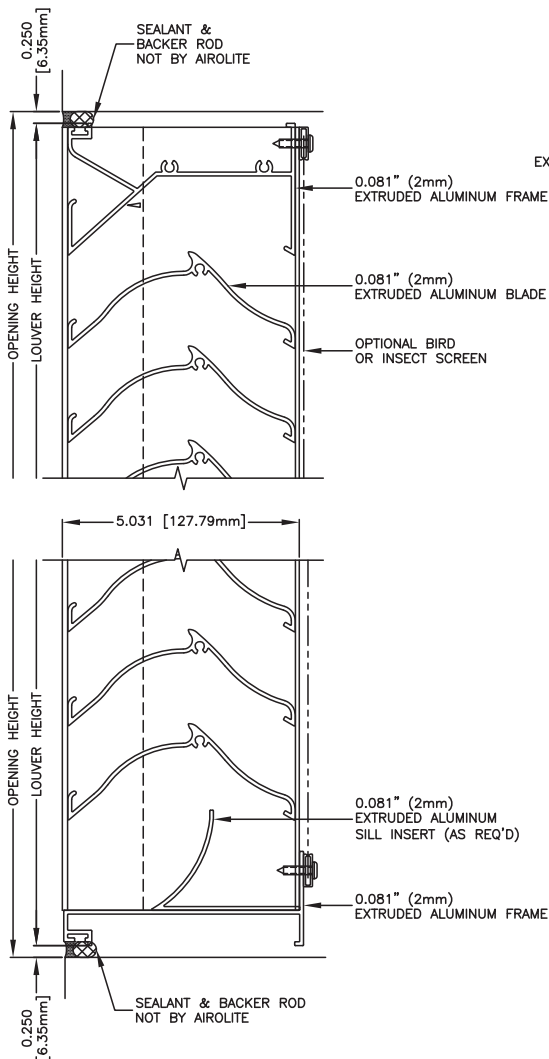

## PLAN SECTION DETAIL

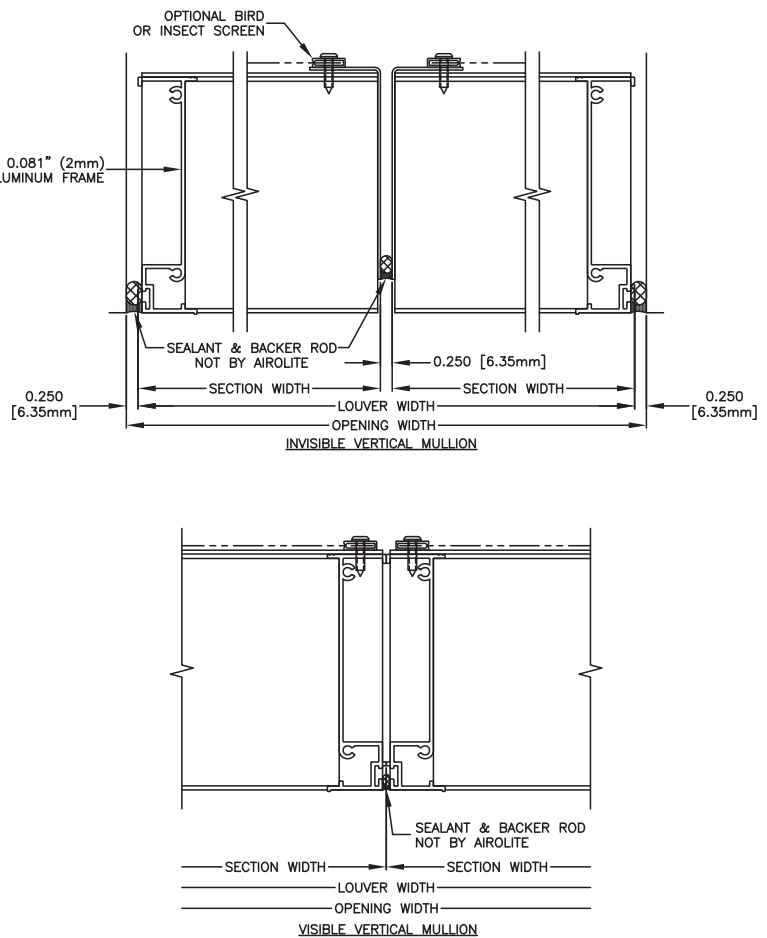

### Minimum Section Size:

12 in. (30 cm) W x 12 in. (30 cm) H

### Maximum Section Size:

120 in. (304 cm) W x 120 in. (304 cm) H

\*one dimension cannot exceed 84 in.

## ACCESSORY ITEMS

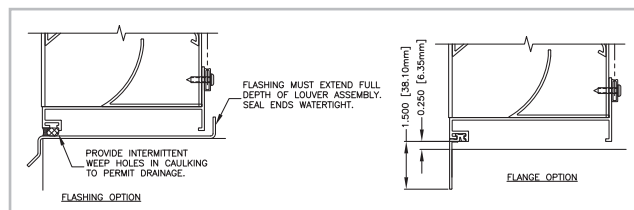

# LOUVER TYPE K605D PERFORMANCE RATINGS

## FREE AREA CHART - in square feet

Louver Height Inches	Louver Width in Inches												
	12	24	30	42	48	60	66	78	84	96	102	114	120
12	0.32	0.74	0.95	1.37	1.58	1.95	2.16	2.57	2.78	3.20	3.41	3.83	3.99
18	0.58	1.33	1.71	2.46	2.84	3.49	3.87	4.62	5.00	5.75	6.12	6.88	7.16
24	0.84	1.92	2.46	3.55	4.09	5.04	5.58	6.67	7.21	8.30	8.84	9.92	10.33
30	1.09	2.51	3.22	4.64	5.35	6.59	7.30	8.71	9.42	10.84	11.55	12.97	13.50
36	1.35	3.10	3.98	5.73	6.60	8.13	9.01	10.76	11.64	13.39	14.26	16.01	16.67
42	1.61	3.69	4.73	6.82	7.86	9.68	10.72	12.81	13.85	15.93	16.98	19.06	19.84
48	1.86	4.28	5.49	7.91	9.11	11.23	12.44	14.85	16.06	18.48	19.69	22.10	23.01
54	2.12	4.87	6.24	8.99	10.37	12.78	14.15	16.90	18.28	21.03	22.40	25.15	26.18
60	2.38	5.46	7.00	10.08	11.63	14.32	15.86	18.95	20.49	23.57	25.11	28.20	29.35
66	2.63	6.05	7.76	11.17	12.88	15.87	17.58	20.99	22.70	26.12	27.83	31.24	32.52
72	2.89	6.64	8.51	12.26	14.14	17.42	19.29	23.04	24.91	28.66	30.51	34.29	35.69
78	3.15	7.23	9.27	13.35	15.39	18.96	21.00	25.09	27.13	31.21	33.25	37.33	38.86
84	3.40	7.82	10.03	14.44	16.65	20.51	22.72	27.13	29.34	33.76	35.96	40.38	42.03
90	3.66	8.41	10.78	15.53	17.90	22.06	24.43	29.18	31.55	36.30	38.68	43.42	45.20
96	3.92	9.00	11.54	16.62	19.16	23.61	26.15	31.23	33.78	38.85	41.39	46.47	48.37
102	4.17	9.59	12.29	17.71	20.41	25.15	27.86	33.27	35.98	41.39	44.10	49.51	51.54
108	4.43	10.18	13.05	18.80	21.67	26.70	29.57	35.32	38.19	43.94	46.81	52.56	54.72
114	4.69	10.77	13.81	19.89	22.93	28.25	31.29	37.37	40.41	43.49	49.53	55.61	57.89
120	4.94	11.36	14.56	20.98	24.18	29.79	33.00	39.41	42.62	49.03	52.24	58.65	61.06



The Airlite Company, LLC certifies that Louver Type K605D shown herein is licensed to bear the AMCA seal. The ratings shown are based on tests and procedures performed in accordance with AMCA Publication 511 and comply with the requirements of the AMCA Certified Ratings Program. The AMCA Certified Ratings Seal applies only to Air Performance and Water Penetration ratings.

### AIRFLOW RESISTANCE

(Standard Air - .075 lb./ft.<sup>3</sup>)

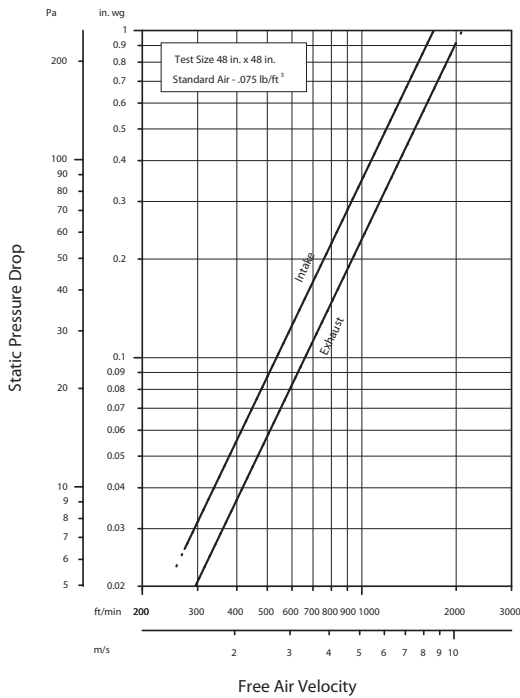

Louver Type K605D resistance to airflow is shown with louver blades fully open. Resistance (pressure drop) varies depending on louver application (air intake or air exhaust). Free area velocities (shown) are higher than average velocity through the overall louver size.

### WATER PENETRATION

(Standard Air - .075 lb./ft.<sup>3</sup>)

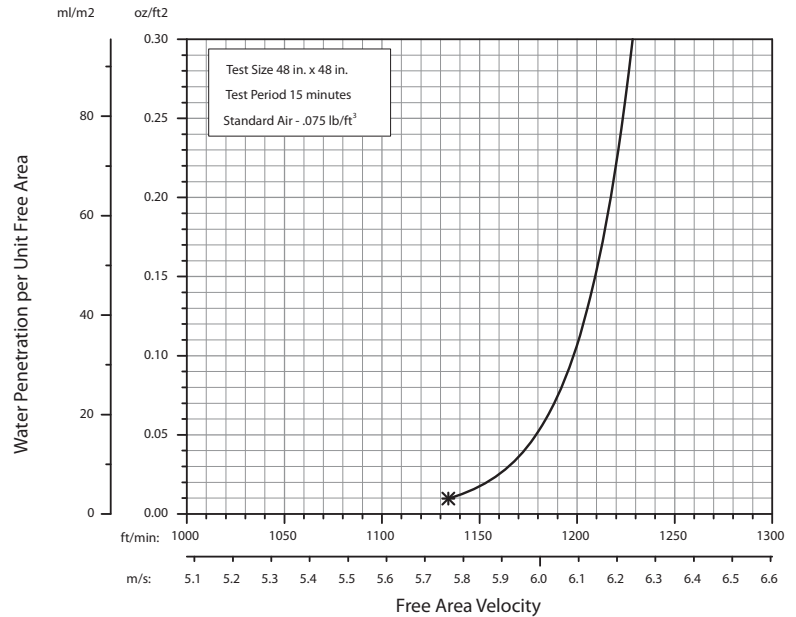

The AMCA Water Penetration Test provides a method for comparing various louver models and designs as to their efficiency in resisting the penetration of rainfall under specific laboratory test conditions. The point of zero water penetration is defined as that velocity where the water penetration curve projects through .01 oz. of water (penetration) per sq. ft. of louver free area. **\*The beginning point of water penetration for Louver Type K605D is 1134 fpm free area velocity.** These performance ratings do not guarantee a louver to be weatherproof or stormproof and should be used in combination with other factors including good engineering judgement in selecting louvers.

# LOUVER TYPE K605D METHOD OF INSTALLATION & ACCESSORY OPTIONS

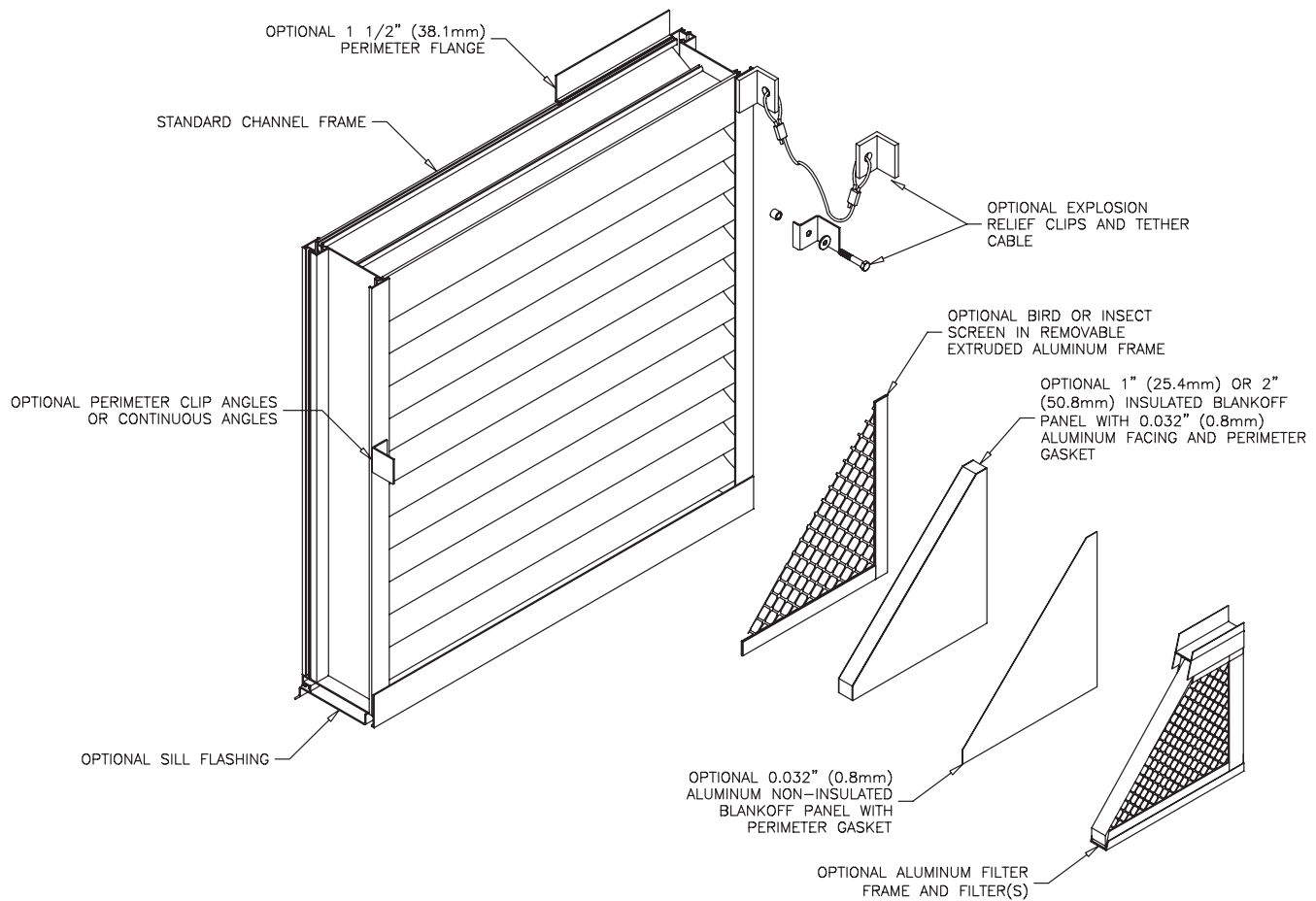

## FINISHES (Select one of the following)

**ACRYLIC ENAMEL:** Louvers shall be cleaned, pretreated and Finished with an oven-cured thermosetting acrylic enamel finish that meets or exceeds the performance requirements of AAMA 2603, "Voluntary Specification Performance Requirements and Test Procedures for Pigmented Organic Coatings."

**2-COAT FLUOROPOLYMER:** Louvers shall be cleaned, pretreated and Finished with an inhibitive primer and oven-cured Kynar 500® / Hylar 5000® resin coating with minimum 1.2 mils dry-film coating thickness that meets or exceeds the performance requirements of AAMA 2605, "Voluntary Specification, Performance Requirements and Test Procedures for Superior Performance Organic Coatings on Aluminum Extrusions and Panels."

**3-COAT FLUOROPOLYMER:** Louvers shall be cleaned, pretreated and Finished with an inhibitive primer and oven-cured Kynar 500® / Hylar 5000® resin coating with minimum 2.0 mils dry-film coating thickness that meets or exceeds the performance requirements of AAMA 2605, "Voluntary Specification, Performance Requirements and Test Procedures for Superior Performance Organic Coatings on Aluminum Extrusions and Panels."

**CLEAR ANODIZE:** Louvers shall be Finished with a Class I clear anodized coating (AA-M10C22A41) that complies with the performance requirements of AAMA Specification 611-98, "Voluntary Specification for Anodized Architectural Aluminum."

**COLOR ANODIZE:** Louvers shall be Finished with a Class I electrolytically color anodized coating (AA-M10C22A42/44) that complies with the performance requirements of AAMA Specification 611-98, "Voluntary Specification for Anodized Architectural Aluminum." Color shall be (select one): Champagne, Light Bronze, Medium Bronze, Dark Bronze, Extra Dark Bronze or Black Anodize.



P.O. Box 410, 525 Western Road, Schofield, WI 54476-0410 USA  
715.841.8757 • fax 715.841.8773 • www.airolite.com

Submittal K605D June 2006, Revision 1  
Copyright ©2006 The Airolite Company, LLC

The Airolite Company, LLC reserves the right to make product changes.