

EXTRUDED ALUMINUM NARROW PROFILE LOUVER

Visible Mullion Louver Type	AC420
Continuous Blade Louver Type	CB420
Frameless Louver Type	AC420S
Material	Extruded Aluminum (Alloy 6063-T5)
Stationary Blade	0.063 in. (1.6 mm)
Frame	0.063 in. (1.6 mm)
Louver Depth	1.5 in. (38.1 mm)
Blade Angle	52°
Free Area – 4 ft. x 4 ft. Unit	7.40 sq. ft. (0.69 sq m)
Percent Free Area	46.3%
Free Area Velocity at Beginning Point of Water Penetration – 0.01 oz H₂O/sq. ft. Free Area	
not rated	
Air Volume Flow Rate at Beginning Point of Water Penetration – 4 ft. x 4 ft. Unit	
not rated	
Pressure Drop at Beginning Point of Water Penetration	
not rated	

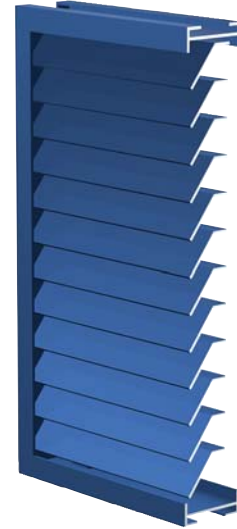
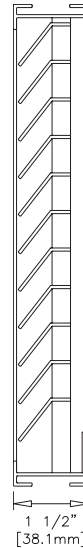

RECOMMENDED SPECIFICATION

GENERAL

Furnish and install where indicated on plans or described in schedules Louver Type AC420 (or CB420) as designed and manufactured by The Airlite Company LLC, Schofield, Wisconsin. Louvers shall be furnished with bird screen, insect screen, supports, installation hardware and finishes as specified and as required for a complete installation.

SUBMITTALS

Manufacturer shall submit shop drawings incorporating key plans, elevations, sections and details showing profiles, angles and spacing of louver blades and frames; unit dimensions related to wall openings and construction; and, anchorage details and locations. Provide samples of manufacturer's finish and color charts showing the full range of colors available.

PRODUCTS

Louvers shall be Airlite Louver Type AC420 with visible vertical mullions (or Louver Type CB420 with concealed vertical mullions). Louvers shall be 1-1/2-inches (38.1 mm) deep and assembled entirely from extruded aluminum components. Blades and frames shall be 0.063-inch (1.60 mm) thick extruded aluminum, alloy 6063-T5. Blades shall be stationary, horizontal and spaced 0.75-inch (19.05 mm) on center.

STRUCTURAL DESIGN CRITERIA

Louvers larger than 96-inches wide x 48-inches high will be fabricated and installed in multiple sections, but limited to one section high.

PERFORMANCE RATINGS

FREE AREA:	7.40 Square Feet (0.69 m ²)
MINIMUM FREE AREA VELOCITY at Beginning Point of Water Penetration:	not rated
MINIMUM AIR VOLUME FLOW RATE at Beginning Point of Water Penetration:	not rated
PRESSURE DROP at Beginning Point of Water Penetration:	not rated

See page 4 for complete finish options

LOUVER TYPE AC420 PRODUCT DESCRIPTION & DETAILS

AIROLITE LOUVER TYPE AC420 is a versatile, horizontal blade, 1-1/2-inch (38.1 mm) deep architectural grille suitable for applications where high free area is required to support maximum air volume flow rates and weather protection is not a concern. Louver Type AC420 is available with both visible and concealed vertical mullions to complement and enhance exterior façade elements. Specify Louver Type AC420 with visible vertical mullions; and, Louver Type CB420 with concealed vertical mullions. Louver Type AC420S is similar but is furnished with no perimeter frame. Please contact your local Airolite representative or the factory for assistance with the layout and design of supports systems when required.

VERTICAL SECTION DETAIL

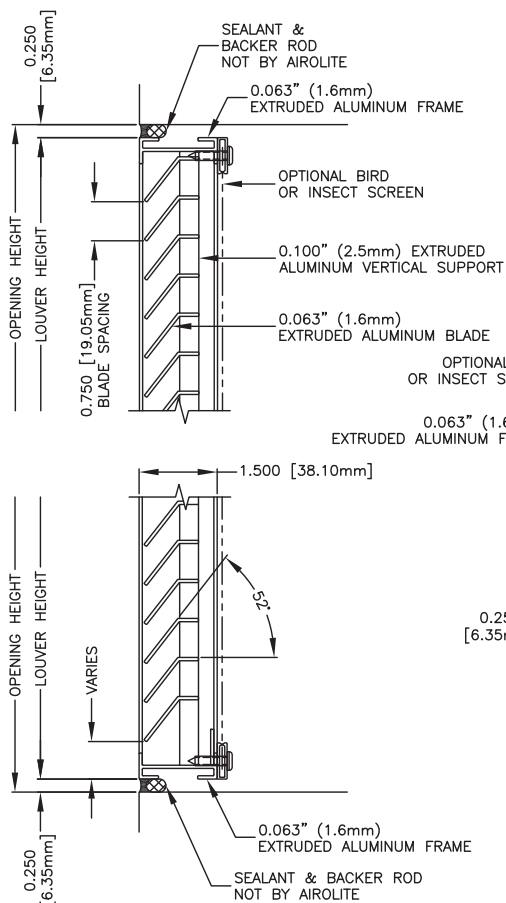

PLAN SECTION DETAIL

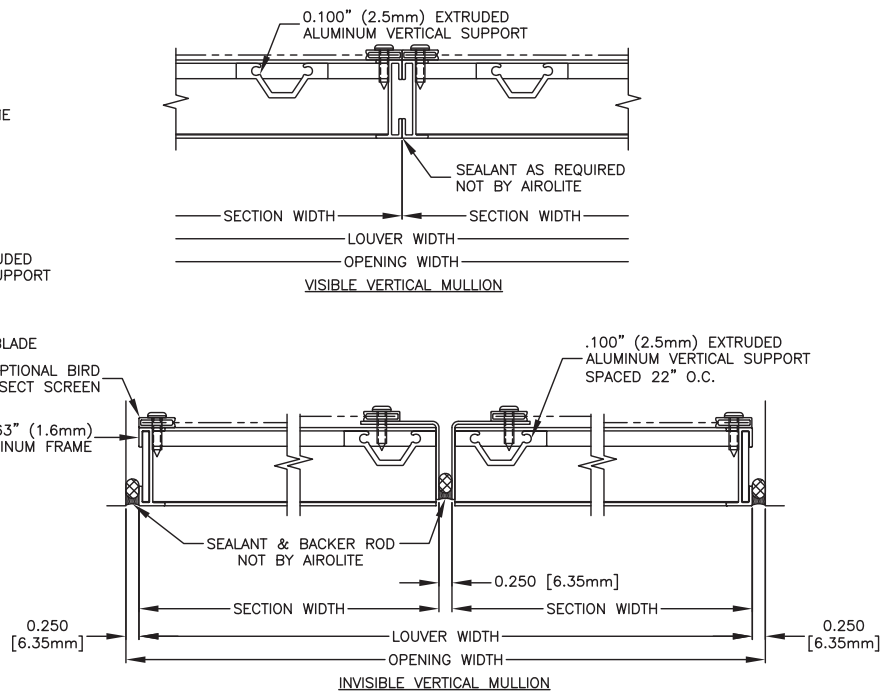

ACCESSORY ITEMS

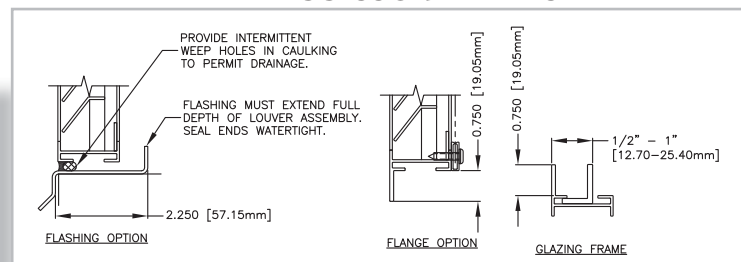

Minimum Section Size:

13.5 in. (34 cm) W x 10 in. (25 cm) H without Flange

13.5 in. (34 cm) W x 12 in. (31 cm) H with Flange

Maximum Section Size:

96 in. (244 cm) W x 48 in. (122 cm) H

LOUVER TYPE AC420 PERFORMANCE RATINGS

FREE AREA CHART - in square feet

Louver Height Inches	Louver Width in Inches															
	10	12	18	24	30	36	42	48	54	60	66	72	78	84	90	96
10	0.18	0.24	0.41	0.60	0.78	0.97	1.15	1.34	1.47	1.66	1.84	2.03	2.23	2.34	2.53	2.72
12	0.22	0.30	0.51	0.74	0.97	1.20	1.43	1.67	1.83	2.06	2.29	2.52	2.78	2.92	3.15	3.38
15	0.28	0.38	0.66	0.95	1.25	1.55	1.85	2.14	2.35	2.65	2.95	3.25	3.58	3.75	4.05	4.35
18	0.35	0.47	0.80	1.17	1.53	1.89	2.26	2.62	2.88	3.24	3.61	3.97	4.38	4.59	4.95	5.32
21	0.41	0.55	0.95	1.38	1.81	2.24	2.67	3.10	3.41	3.83	4.26	4.70	5.17	5.43	5.86	6.29
24	0.47	0.64	1.10	1.59	2.09	2.59	3.08	3.58	3.93	4.43	4.92	5.42	5.97	6.27	6.76	7.26
27	0.54	0.72	1.24	1.81	2.37	2.93	3.50	4.06	4.46	5.02	5.58	6.15	6.77	7.11	7.67	8.23
30	0.60	0.81	1.39	2.02	2.64	3.27	3.90	4.53	4.97	5.60	6.23	6.86	7.56	7.93	8.56	9.18
33	0.66	0.89	1.53	2.23	2.92	3.62	4.31	5.01	5.50	6.19	6.89	7.58	8.36	8.77	9.46	10.16
36	0.72	0.98	1.68	2.44	3.20	3.96	4.72	5.49	6.02	6.78	7.54	8.31	9.16	9.61	10.36	11.13
39	0.79	1.06	1.83	2.65	3.48	4.31	5.14	5.96	6.55	7.37	8.20	9.03	9.96	10.44	11.27	12.10
42	0.85	1.15	1.97	2.87	3.76	4.65	5.55	6.44	7.08	7.87	8.66	9.76	10.76	11.28	12.17	13.07
45	0.91	1.23	2.12	3.08	4.04	5.00	5.96	6.92	7.60	8.56	9.52	10.48	11.55	12.12	13.08	14.04
48	0.98	1.32	2.27	3.29	4.32	5.34	6.37	7.40	8.13	9.15	10.18	11.21	12.35	12.96	13.98	15.01

AIRFLOW RESISTANCE (Standard Air - .075 lb./ft.³)

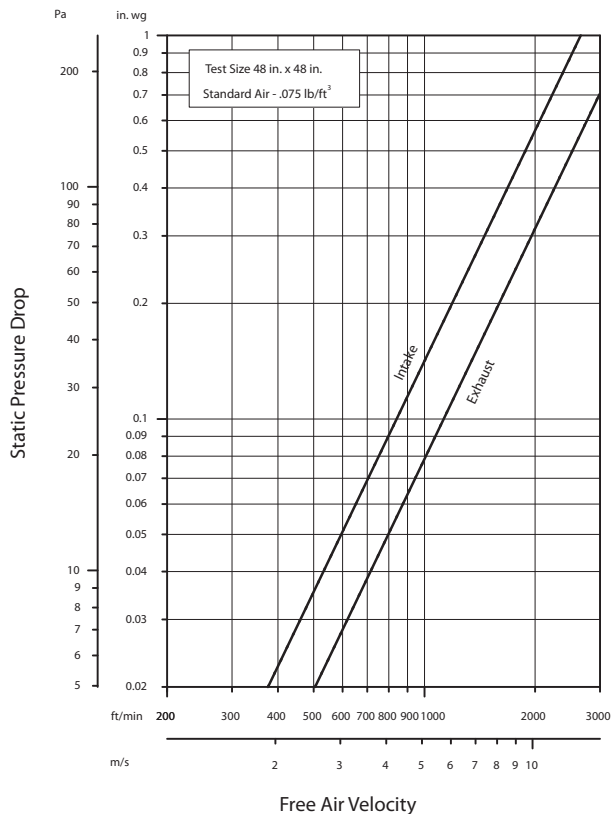

Louver Type AC420 resistance to airflow (pressure drop) varies depending on louver application (air intake or air exhaust). Free area velocities (shown) are higher than average velocity through the overall louver size.

LOUVER TYPE AC420 METHOD OF INSTALLATION & ACCESSORY OPTIONS

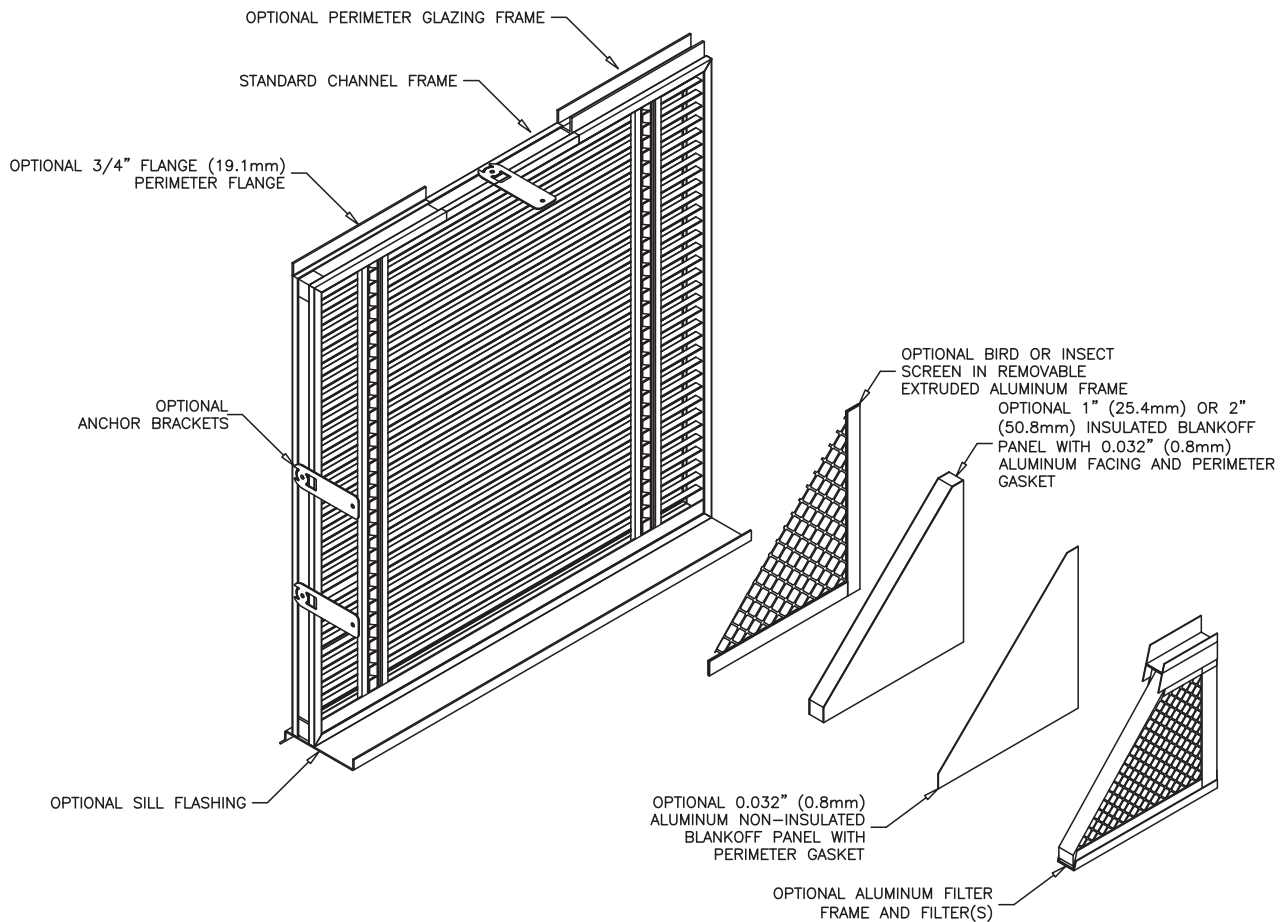

FINISHES (Select one of the following)

ACRYLIC ENAMEL: Louvers shall be cleaned, pretreated and FINISHED-AFTER-ASSEMBLY with an oven-cured thermosetting acrylic enamel finish that meets or exceeds the performance requirements of AAMA 2603, "Voluntary Specification Performance Requirements and Test Procedures for Pigmented Organic Coatings."

2-COAT FLUOROPOLYMER: Louvers shall be cleaned, pretreated and FINISHED-AFTER-ASSEMBLY with an inhibitive primer and oven-cured Kynar 500® / Hylar 5000® resin coating with minimum 1.2 mils dry-film coating thickness that meets or exceeds the performance requirements of AAMA 2605, "Voluntary Specification, Performance Requirements and Test Procedures for Superior Performance Organic Coatings on Aluminum Extrusions and Panels."

3-COAT FLUOROPOLYMER: Louvers shall be cleaned, pretreated and FINISHED-AFTER-ASSEMBLY with an inhibitive primer and oven-cured Kynar 500® / Hylar 5000® resin coating with minimum 2.0 mils dry-film coating thickness that meets or exceeds the performance requirements of AAMA 2605, "Voluntary Specification, Performance Requirements and Test Procedures for Superior Performance Organic Coatings on Aluminum Extrusions and Panels."

CLEAR ANODIZE: Louvers shall be FINISHED-AFTER-ASSEMBLY with a Class I clear anodized coating (AA-M10C22A41) that complies with the performance requirements of AAMA Specification 611-98, "Voluntary Specification for Anodized Architectural Aluminum."

COLOR ANODIZE: Louvers shall be FINISHED-AFTER-ASSEMBLY with a Class I electrolytically color anodized coating (AA-M10C22A42/44) that complies with the performance requirements of AAMA Specification 611-98, "Voluntary Specification for Anodized Architectural Aluminum." Color shall be (select one): Champagne, Light Bronze, Medium Bronze, Dark Bronze, Extra Dark Bronze or Black Anodize.



P.O. Box 410, 525 Western Road, Schofield, WI 54476-0410 USA
715.841.8757 • fax 715.841.8773 • www.airolite.com

Submittal AC420 May 2006, Revision 3
Copyright ©2006 The Airolite Company, LLC

The Airolite Company, LLC reserves the right to make product changes.