

## EXTRUDED ALUMINUM NARROW PROFILE LOUVER

<b>Visible Mullion Louver Type</b> .....	T63815
<b>Continuous Blade Louver Type</b> .....	CB63815
<b>Material</b> .....	Extruded Aluminum (Alloy 6063-T5)
<b>Stationary Blade</b> .....	0.063 in. (1.6 mm)
<b>Frame</b> .....	0.063 in. (1.6 mm)
<b>Louver Depth</b> .....	1.5 in. (38.1 mm)
<b>Blade Angle</b> .....	30°
<b>Free Area – 4 ft. x 4 ft. Unit</b> .....	7.29 sq. ft. (0.68 sq m)
<b>Percent Free Area</b> .....	45.6%
<b>Free Area Velocity at Beginning Point of Water Penetration – 0.01 oz H<sub>2</sub>O/sq. ft. Free Area</b> .....	not rated
<b>Air Volume Flow Rate at Beginning Point of Water Penetration – 4 ft. x 4 ft. Unit</b> .....	not rated
<b>Pressure Drop at Beginning Point of Water Penetration</b> .....	not rated

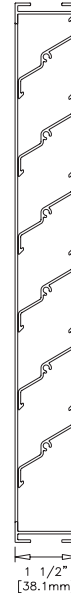

### RECOMMENDED SPECIFICATION

#### GENERAL

Furnish and install where indicated on plans or described in schedules Louver Type T63815 (or CB63815) as designed and manufactured by The AiroLite Company LLC, Schofield, Wisconsin. Louvers shall be furnished with bird screen, insect screen, supports, installation hardware and finishes as specified and as required for a complete installation.

#### SUBMITTALS

Manufacturer shall submit shop drawings incorporating key plans, elevations, sections and details showing profiles, angles and spacing of louver blades and frames; unit dimensions related to wall openings and construction; and, anchorage details and locations. Provide samples of manufacturer's finish and color charts showing the full range of colors available.

#### PRODUCTS

Louvers shall be architectural blade Louver Type T63815 with visible vertical mullions (or Louver Type CB63815 with concealed vertical mullions). Louvers shall be 1-1/2-inches (38.1 mm) deep and assembled entirely from extruded aluminum components. Blades and frames shall be 0.063-inch (1.6 mm) thick extruded aluminum, alloy 6063-T5. Blades shall be stationary, horizontal and spaced 1-7/8-inches (47.6 mm) on center.

#### STRUCTURAL DESIGN CRITERIA

Louvers larger than 48-inches wide x 60-inches high will be fabricated and installed in multiple sections, but limited to one section high.

#### PERFORMANCE RATINGS

FREE AREA:	7.29 Square Feet (0.68 m <sup>2</sup> )
MINIMUM FREE AREA VELOCITY at Beginning Point of Water Penetration:	not rated
MINIMUM AIR VOLUME FLOW RATE at Beginning Point of Water Penetration:	not rated
PRESSURE DROP at Beginning Point of Water Penetration:	not rated

See page 4 for complete finish options

# LOUVER TYPE T63815 PRODUCT DESCRIPTION & DETAILS

**AIROLITE LOUVER TYPE T63815** is a versatile, horizontal blade, 1-1/2-inch (38.1 mm) deep architectural louver suitable for applications with narrow or short openings that require greater free area than a four or six-inch deep louver can provide and weather protection is not a concern. Louver Type T63815 is available with both visible and concealed vertical mullions to complement and enhance exterior façade elements. Specify Louver Type T63815 with visible vertical mullions; and, Louver Type CB63815 with concealed vertical mullions. Please contact your local Airlite representative or the factory for assistance with the layout and design of support systems when required.

## VERTICAL SECTION DETAIL

## PLAN SECTION DETAIL

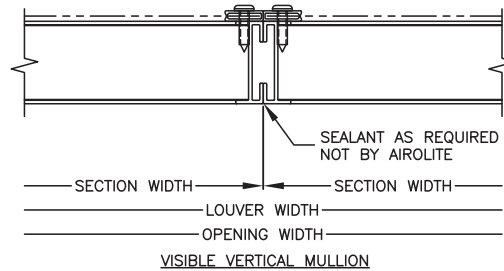
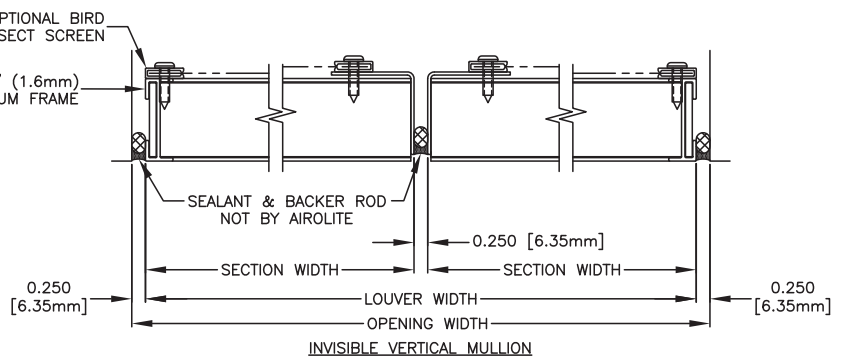
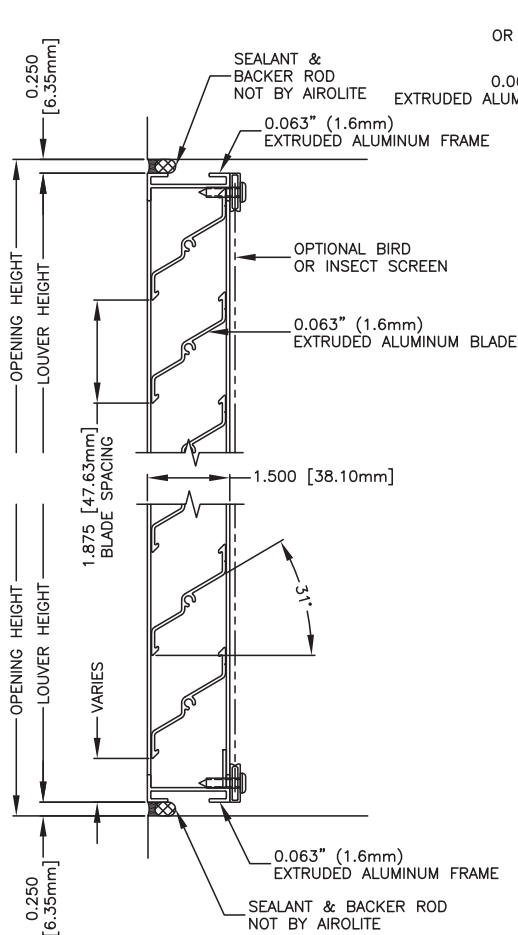

### Minimum Section Size:

- 10 in. (25 cm) W x 10 in. (25 cm) H without flange
- 12 in. (31 cm) W x 12 in. (31 cm) H with flange

### Maximum Section Size:

- 48 in. (122 cm) W x 60 in. (152 cm) H

## ACCESSORY ITEMS

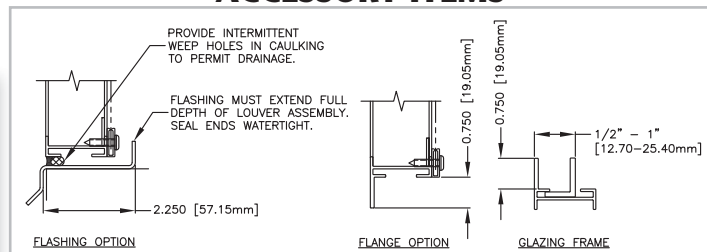

# LOUVER TYPE T63815 PERFORMANCE RATINGS

## FREE AREA CHART - in square feet

Louver Height Inches	Louver Width in Inches							
	10	12	18	24	30	36	42	48
10	0.23	0.29	0.45	0.60	0.76	0.92	1.06	1.22
12	0.29	0.36	0.56	0.76	0.95	1.15	1.33	1.53
15	0.39	0.48	0.74	1.01	1.27	1.54	1.77	2.04
18	0.46	0.57	0.88	1.20	1.52	1.83	2.11	2.43
21	0.58	0.71	1.11	1.51	1.90	2.30	2.65	3.04
24	0.65	0.80	1.25	1.70	2.15	2.59	2.99	3.43
27	0.75	0.92	1.44	1.96	2.47	2.99	3.44	3.95
30	0.85	1.04	1.62	2.20	2.78	3.36	3.87	4.45
33	0.92	1.14	1.77	2.40	3.03	3.67	4.22	4.86
36	1.04	1.28	1.99	2.71	3.42	4.13	4.76	5.47
39	1.11	1.37	2.13	2.90	3.66	4.42	5.09	5.85
42	1.22	1.49	2.33	3.16	3.99	4.82	5.55	6.38
45	1.31	1.61	2.51	3.41	4.30	5.20	5.98	6.88
48	1.39	1.70	2.65	3.61	4.55	5.50	6.34	7.29
51	1.50	1.85	2.88	3.91	4.94	5.97	6.87	7.90
54	1.58	1.94	3.02	4.10	5.17	6.25	7.20	8.28
57	1.68	2.06	3.21	4.36	5.51	6.66	7.66	8.81
60	1.77	2.18	3.39	4.60	5.81	7.03	8.09	9.30

## AIRFLOW RESISTANCE

(Standard Air - .075 lb./ft.<sup>3</sup>)

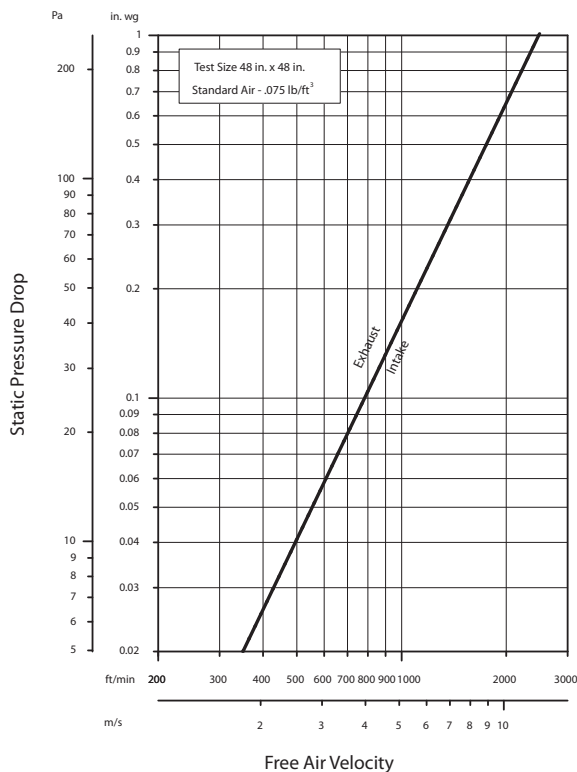

Louver Type T63815 resistance to airflow (pressure drop) varies depending on louver application (air intake or air exhaust). Free area velocities (shown) are higher than average velocity through the overall louver size.

# LOUVER TYPE T63815 METHOD OF INSTALLATION & ACCESSORY OPTIONS

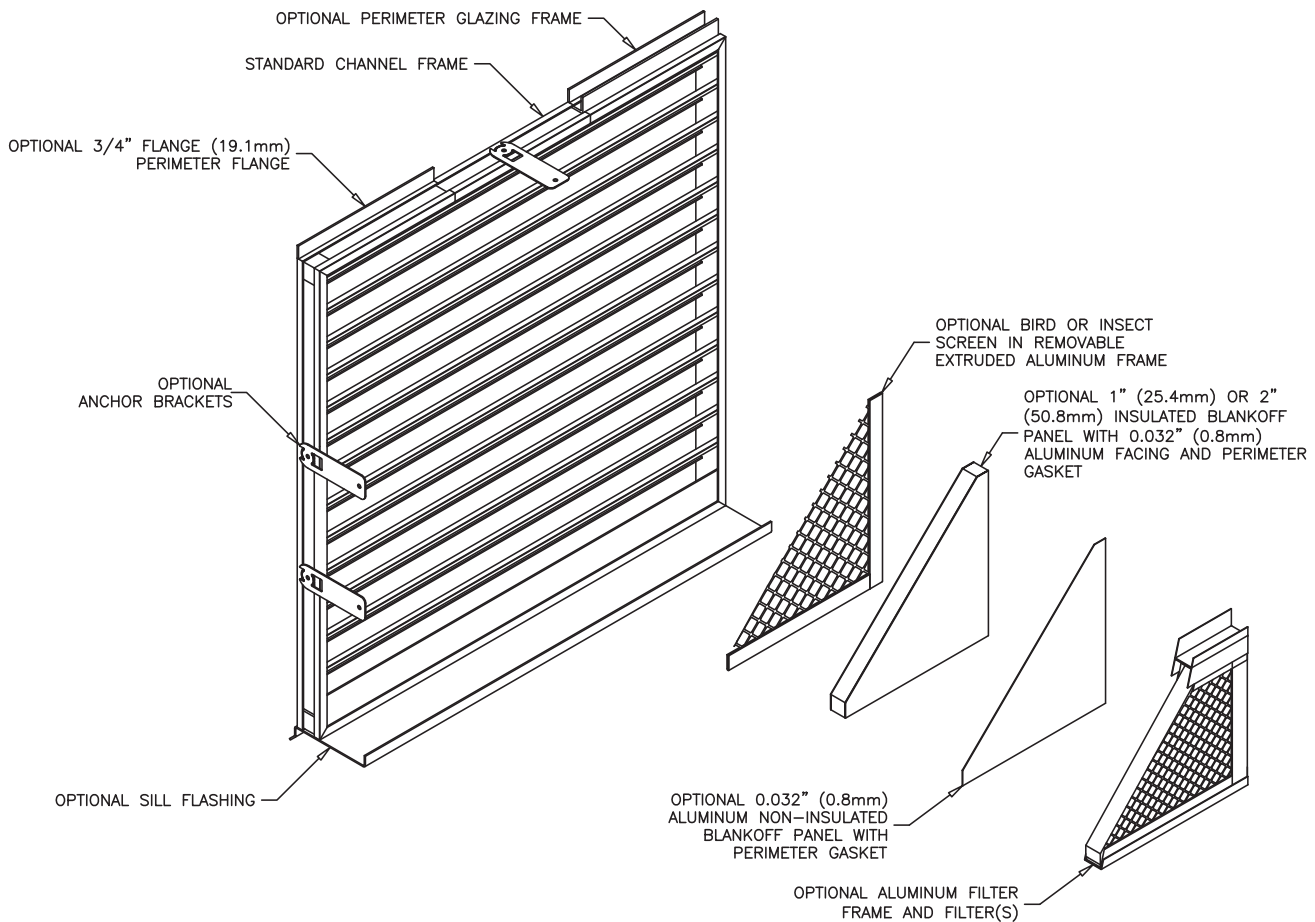

## FINISHES (Select one of the following)

**ACRYLIC ENAMEL:** Louvers shall be cleaned, pretreated and FINISHED-AFTER-ASSEMBLY with an oven-cured thermosetting acrylic enamel finish that meets or exceeds the performance requirements of AAMA 2603, "Voluntary Specification Performance Requirements and Test Procedures for Pigmented Organic Coatings."

**2-COAT FLUOROPOLYMER:** Louvers shall be cleaned, pretreated and FINISHED-AFTER-ASSEMBLY with an inhibitive primer and oven-cured Kynar 500® / Hylar 5000® resin coating with minimum 1.2 mils dry-film coating thickness that meets or exceeds the performance requirements of AAMA 2605, "Voluntary Specification, Performance Requirements and Test Procedures for Superior Performance Organic Coatings on Aluminum Extrusions and Panels."

**3-COAT FLUOROPOLYMER:** Louvers shall be cleaned, pretreated and FINISHED-AFTER-ASSEMBLY with an inhibitive primer and oven-cured Kynar 500® / Hylar 5000® resin coating with minimum 2.0 mils dry-film coating thickness that meets or exceeds the performance requirements of AAMA 2605, "Voluntary Specification, Performance Requirements and Test Procedures for Superior Performance Organic Coatings on Aluminum Extrusions and Panels."

**CLEAR ANODIZE:** Louvers shall be FINISHED-AFTER-ASSEMBLY with a Class I clear anodized coating (AA-M10C22A41) that complies with the performance requirements of AAMA Specification 611-98, "Voluntary Specification for Anodized Architectural Aluminum."

**COLOR ANODIZE:** Louvers shall be FINISHED-AFTER-ASSEMBLY with a Class I electrolytically color anodized coating (AA-M10C22A42/44) that complies with the performance requirements of AAMA Specification 611-98, "Voluntary Specification for Anodized Architectural Aluminum." Color shall be (select one): Champagne, Light Bronze, Medium Bronze, Dark Bronze, Extra Dark Bronze or Black Anodize.



P.O. Box 410, 525 Western Road, Schofield, WI 54476-0410 USA  
715.841.8757 • fax 715.841.8773 • www.airolite.com

Submission T63815 May 2006, Revision 4  
Copyright ©2006 The Airlite Company, LLC

The Airlite Company, LLC reserves the right to make product changes.