



## STORM CLASS™ LOUVER

<b>Visible Mullion Louver Type</b> .....	SCC875
<b>Material</b> .....	Extruded Aluminum (Alloy 6063-T5)
<b>Stationary Blade</b> .....	0.081 in. (2.06 mm)
<b>Frame</b> .....	0.081 in. (2.06 mm)
<b>Louver Depth</b> .....	8 3/4 in. (222.3 mm)
<b>Free Area – 4 ft. x 4 ft. Unit</b> .....	8.62 sq. ft. (0.987 m <sup>2</sup> )
<b>Percent Free Area</b> .....	53.9%
<b>Free Area Velocity at Beginning Point of Water Penetration – 0.01 oz H<sub>2</sub>O/sq. ft. Free Area</b> ... above 1,250 fpm (6.35 m/s)	
<b>Air Volume Flow Rate at Beginning Point of Water Penetration – 4 ft. x 4 ft. Unit</b> .... 10,775 cfm (5.09 m <sup>3</sup> /s)	
<b>Pressure Drop at Beginning Point of Water Penetration</b> .....	
	0.30 in. H <sub>2</sub> O (0.075 kPa)

### Wind-Driven Rain Water Penetration Data

Exterior Wind Velocity .....	29 mph (13 m/s)
Rainfall Rate .....	3 in. (75 mm)/hour
Effectiveness .....	100.0%
Core Ventilation Rate .....	982 fpm (5.0 m/s)
Exterior Wind Velocity .....	
	50 mph (22 m/s)
Rainfall Rate .....	8 in. (200 mm)/hour
Effectiveness .....	100.0%
Core Ventilation Rate .....	966 fpm (4.9 m/s)

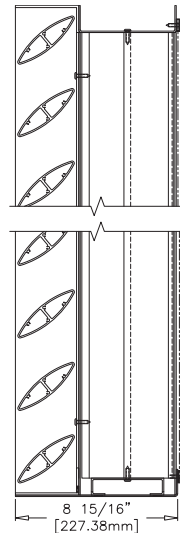

## RECOMMENDED SPECIFICATION

### GENERAL

Furnish and install where indicated on plans or described in schedules Storm Class™ Louver Type SCC875 as designed and manufactured by The Airlite Company LLC, Schofield, Wisconsin. Louvers shall be furnished with bird screen, insect screen, supports, installation hardware and finishes as specified and as required for a complete installation.

### SUBMITTALS

Manufacturer shall submit shop drawings incorporating key plans, elevations, sections and details showing profiles, angles and spacing of louver blades and frames; unit dimensions related to wall openings and construction; and, anchorage details and locations. Submit theoretical calculations prepared by a professional engineer specializing in the application of welding technology demonstrating that each fillet weld joining blade and frame members will withstand a minimum of 526 pounds of force in shear. Provide samples of manufacturer's finish and color charts showing the full range of colors available. For each type of product specified, submit free area, air performance, water penetration and wind-driven rain ratings determined in accordance with AMCA Standard 500-L 99 and licensed under the AMCA Certified Ratings Program.

### PRODUCTS

Louvers shall be Storm Class™ type and rated to resist water penetration under wind-driven rain conditions. Louvers shall be 8 3/4-inches (222.25 mm) deep and assembled from both extruded aluminum and fabricated components. Exterior blades and frames shall be 0.081-inch (2 mm) thick extruded aluminum, alloy 6063-T5. Interior blades shall be 0.081-inch (2 mm) extruded aluminum, alloy 6063-T5. Exterior blades shall be horizontal and spaced 4-inches (101.6 mm) on center.

### STRUCTURAL DESIGN CRITERIA

Manufacturer shall design and furnish all supports required to withstand a wind force of not less than 25 pounds per square foot. Louvers larger than 72-inches (183 cm) wide x 72-inches (183 cm) high will be fabricated and installed in multiple sections. Louver blades, frames, mullions and anchorages shall be demonstrated to withstand the specified wind design load.

### PERFORMANCE RATINGS

FREE AREA:	8.62 Square Feet ( 0.987 m <sup>2</sup> )
MINIMUM FREE AREA VELOCITY	
at Beginning Point of Water Penetration:	1,250 fpm (6.35 m/s)
MINIMUM AIR VOLUME FLOW RATE	
at Beginning Point of Water Penetration:	10,775 cfm (5.09 m <sup>3</sup> /s)
MAXIMUM STATIC PRESSURE	
at Beginning Point of Water Penetration:	0.30 in. H <sub>2</sub> O (0.075 kPa)

See page 3 for Wind-driven Rain Performance  
See page 4 for complete finish options

# LOUVER TYPE SCC875 PRODUCT DESCRIPTION & DETAILS

Airolite Storm Class™ combination louvers are designed and rated to provide high volume intake and exhaust ventilation and the greatest level of protection against water penetration available even under the most severe wind-driven rain conditions. Airolite Storm Class™ combination louvers incorporate exterior and interior louver modules that afford the designer optimum flexibility in aesthetics, economics and performance. The exterior module allows the designer to present a wide range of conventional to non-traditional appearances. The interior module incorporates a highly efficient blade configuration that yields high ventilation rates and presents a formidable barrier to water penetration. Where there are large inactive louver areas, the interior module may be omitted and the exterior module fitted with blank-off panels to achieve economy. Louver Type SCC875 is a 8-3/4-inch (222.25 mm) deep louver rated to be 100% effective at a core ventilation rate of 966 fpm (4.9 m/s) when tested at a wind velocity of 50 mph (22 m/s) and 8-inch (200 mm) per hour rainfall. Airolite Storm Class™ Louver Type SCC875 is a highly effective barrier to water penetration with AMCA Licensed Air Performance, Water Penetration and Wind-driven Rain performance ratings that enable designers to select and specify this product with confidence. Please contact your local Airolite representative or the factory for assistance with the layout and design of support systems when required.

## VERTICAL SECTION DETAIL

## PLAN SECTION DETAIL

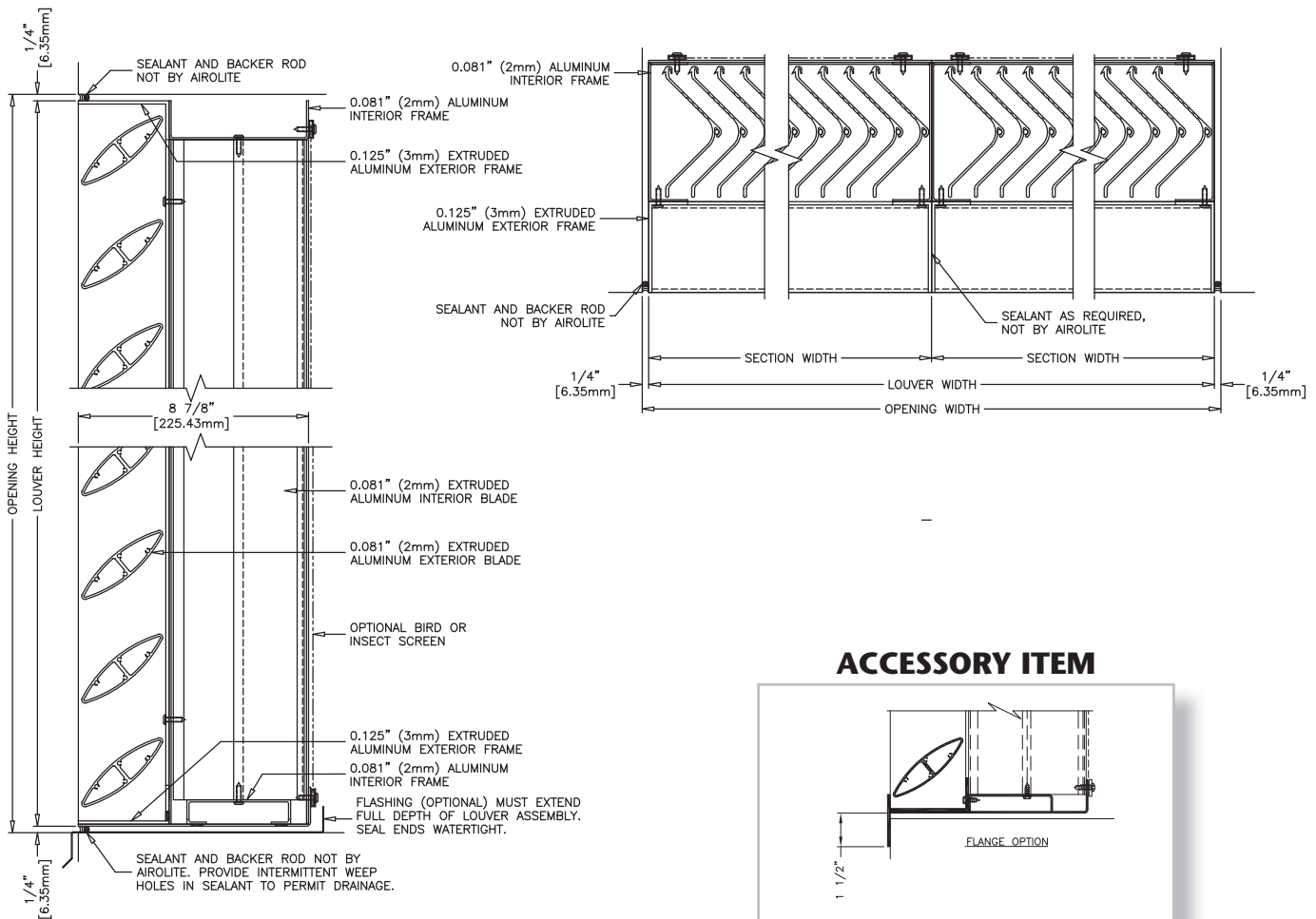

### Minimum Section Size:

12 in. (30 cm) W x 12 in. (30 cm) H

### Maximum Section Size:

72 in. (183 cm) W x 72 in. (183 cm) H

# LOUVER TYPE SCC875 PERFORMANCE RATINGS

## FREE AREA CHART - in square feet

Louver Height Inches	Louver Width in Inches					
	12	24	36	48	60	72
12	0.35	0.81	1.27	1.73	2.19	2.66
24	0.81	1.88	2.95	4.03	5.10	6.17
36	1.26	2.95	4.64	6.32	8.01	9.69
48	1.72	4.02	6.32	8.62	10.91	13.21
60	2.18	5.09	8.00	10.91	13.82	16.73
72	2.64	6.16	9.68	13.20	16.73	20.25



The Airolite Company, LLC certifies that Louver Type SCC875 shown herein is licensed to bear the AMCA seal. The ratings shown are based on tests and procedures performed in accordance with AMCA Publication 511 and comply with the requirements of the AMCA Certified Ratings Program. The AMCA Certified Ratings Seal applies to Water Penetration, Air Performance and Wind-driven Rain.

## WATER PENETRATION

(Standard Air - .075 lb./ft.<sup>3</sup>)

The AMCA Water Penetration Test provides a method for comparing various louver models and designs as to their efficiency in resisting the penetration of rainfall under specific laboratory test conditions. The beginning point of water penetration is defined as that velocity where the water penetration curve projects through 0.01 oz. of water (penetration) per sq. ft. of louver free area. These performance ratings do not guarantee a louver to be weather-proof or stormproof and should be used in combination with other factors including good engineering judgement in selecting louvers. **\*The beginning point of water penetration for Model SCC875 is above 1250 fpm (6.35 m/s) free area velocity.**

## AIRFLOW RESISTANCE

(Standard Air - .075 lb./ft.<sup>3</sup>)

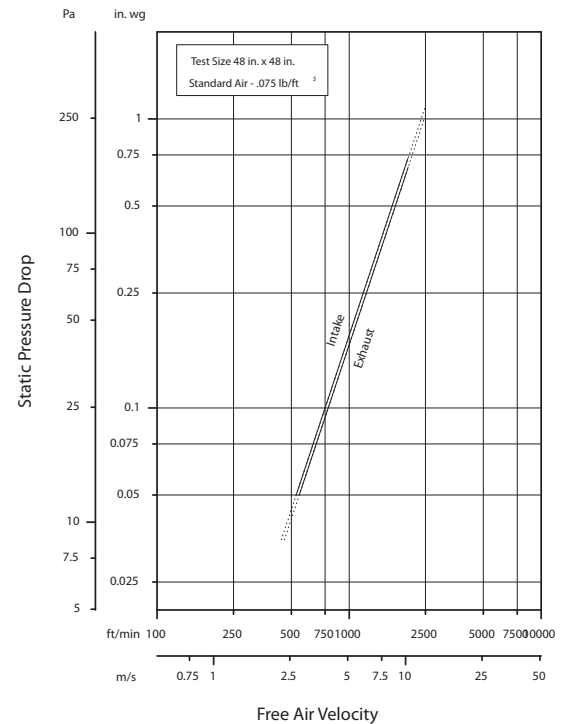

Louver Type SCC875 resistance to airflow varies depending on louver application (air intake or air exhaust). Free area velocities (shown) are higher than the average velocity through the overall louver size.

## WIND-DRIVEN RAIN PERFORMANCE

75mm/h (3 in/hr) Rainfall & 13 m/s (29 mph) Wind Velocity				200mm/h (8 in/hr) Rainfall & 22 m/s (50 mph) Wind Velocity			
Free Area Ventilation Rate (fpm)	Ventilation Air Core Velocity m/s (fpm)	Water Penetration Effect. %	Water Penetration Classification	Free Area Ventilation Rate (fpm)	Ventilation Air Core Velocity m/s (fpm)	Water Penetration Effect. %	Water Penetration Classification
0	0 (0)			0	0 (0)		
180	98 (0.5)			180	98 (0.5)		
361	197 (1.0)			361	197 (1.0)		
541	295 (1.5)			541	295 (1.5)		
722	394 (2.0)			722	394 (2.0)		
902	492 (2.5)			902	492 (2.5)		
1084	591 (3.0)			1084	591 (3.0)		
1263	689 (3.5)			1263	689 (3.5)		
1443	787 (4.0)			1443	787 (4.0)		
1625	886 (4.5)			1625	886 (4.5)		
1801	982 (5.0)	100.0	A	1771	966 (4.9)	100.0	A

Discharge Loss Coefficient Class (Intake) = 3

Weather louvers shall be classified by their ability to reject simulated rain. The table to the left shows different classifications based on the maximum simulated rain penetration per square meter (square feet) of louver. Water penetration rating at a given louver face velocity is determined by the water penetration while the louver is subjected to a selected simulated rainfall rate and wind velocity.

Discharge Loss Coefficient Classifications	
Class	Discharge Loss Coefficient
1	0.4 and Above
2	0.3 to 0.399
3	0.2 to 0.299
4	0.199 and Below

Wind-driven Rain Penetration Classes	
Class	Effectiveness
A	1 to 0.99
B	0.989 to 0.95
C	0.949 to 0.80
D	Below 0.80

# LOUVER TYPE SCC875 METHOD OF INSTALLATION & ACCESSORY OPTIONS

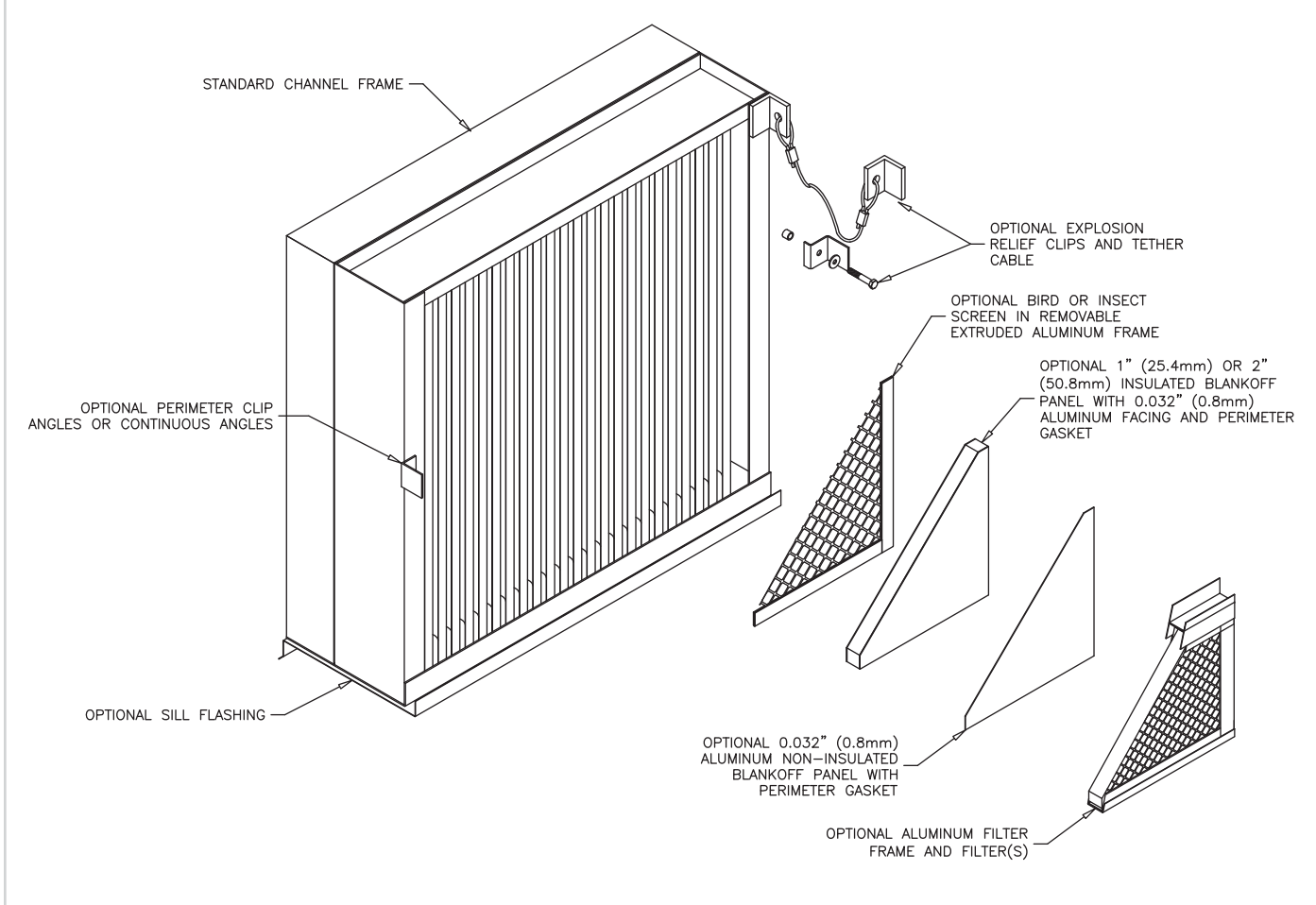

## FINISHES\* (Select one of the following)

**ACRYLIC ENAMEL:** Louvers shall be cleaned, pretreated and FINISHED-AFTER-ASSEMBLY with an oven-cured thermosetting acrylic enamel finish that meets or exceeds the performance requirements of AAMA 2603, "Voluntary Specification Performance Requirements and Test Procedures for Pigmented Organic Coatings."

**2-COAT FLUOROPOLYMER:** Louvers shall be cleaned, pretreated and FINISHED-AFTER-ASSEMBLY with an inhibitive primer and oven-cured Kynar 500® / Hylar 5000® resin coating with minimum 1.2 mils dry-film coating thickness that meets or exceeds the performance requirements of AAMA 2605, "Voluntary Specification, Performance Requirements and Test Procedures for Superior Performance Organic Coatings on Aluminum Extrusions and Panels."

**3-COAT FLUOROPOLYMER:** Louvers shall be cleaned, pretreated and FINISHED-AFTER-ASSEMBLY with an inhibitive primer and oven-cured Kynar 500® / Hylar 5000® resin coating with minimum 2.0 mils dry-film coating thickness that meets or exceeds the performance requirements of AAMA 2605, "Voluntary Specification, Performance Requirements and Test Procedures for Superior Performance Organic Coatings on Aluminum Extrusions and Panels."

**CLEAR ANODIZE:** Louvers shall be FINISHED-AFTER-ASSEMBLY with a Class I clear anodized coating (AA-M10C22A41) that complies with the performance requirements of AAMA Specification 611-98, "Voluntary Specification for Anodized Architectural Aluminum."

**COLOR ANODIZE:** Louvers shall be FINISHED-AFTER-ASSEMBLY with a Class I electrolytically color anodized coating (AA-M10C22A42/44) that complies with the performance requirements of AAMA Specification 611-98, "Voluntary Specification for Anodized Architectural Aluminum." Color shall be (select one): Champagne, Light Bronze, Medium Bronze, Dark Bronze, Extra Dark Bronze or Black Anodize.

\* Finish applied to exterior louver module only. Specify finish applied to interior louver module when required.



P.O. Box 410, 525 Western Road, Schofield, WI 54476-0410 USA  
715.841.8757 • fax 715.841.8773 • www.airolite.com

Submittal SCC875 June 2010  
Copyright ©2010 The Airolite Company, LLC

The Airolite Company, LLC reserves the right to make product changes.