



STORM CLASS[™] LOUVER

Visible Mullion Louver Type	SCH501
Material	Extruded Aluminum (Alloy 6063-T5)
Stationary Blade	0.081 in. (2.06 mm)
Frame	0.081 in. (2.06 mm)
Louver Depth	5 in. (127.0 mm)
Free Area – 4 ft. x 4 ft. Unit	6.80 sq. ft. (0.632 m ²)
Percent Free Area	42.5%
Free Area Velocity at Beginning Point of Water Penetration – 0.01 oz H₂O/sq. ft. Free Area ...	above 1,250 fpm (6.35 m/s)
Air Volume Flow Rate at Beginning Point of Water Penetration – 4 ft. x 4 ft. Unit	8,500 cfm (4.01 m ³ /s)
Pressure Drop at Beginning Point of Water Penetration	0.18 in. H ₂ O (0.045 kPa)

Wind-Driven Rain Water Penetration Data

Exterior Wind Velocity	29 mph (13 m/s)
Rainfall Rate	3 in. (75 mm)/hour
Effectiveness	99.3%
Core Ventilation Rate	876 fpm (4.5 m/s)
Exterior Wind Velocity	50 mph (22 m/s)
Rainfall Rate	8 in. (200 mm)/hour
Effectiveness	98.1%
Core Ventilation Rate	138 fpm (0.7 m/s)

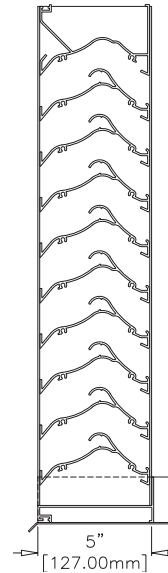

RECOMMENDED SPECIFICATION

GENERAL

Furnish and install where indicated on plans or described in schedules Storm Class[™] Louver Type SCH501 as designed and manufactured by The Airlite Company LLC, Schofield, Wisconsin. Louvers shall be furnished with bird screen, insect screen, supports, installation hardware and finishes as specified and as required for a complete installation.

SUBMITTALS

Manufacturer shall submit shop drawings incorporating key plans, elevations, sections and details showing profiles, angles and spacing of louver blades and frames; unit dimensions related to wall openings and construction; and, anchorage details and locations. Provide samples of manufacturer's finish and color charts showing the full range of colors available. For each type of product specified, submit free area, air performance, water penetration and wind-driven rain ratings determined in accordance with AMCA Standard 500-L 99 and licensed under the AMCA Certified Ratings Program.

PRODUCTS

Louvers shall be Storm Class[™] type and rated to resist water penetration under wind-driven rain conditions. Louvers shall be 5-inches (127 mm) deep and assembled entirely from extruded aluminum components. Blades and frames shall be 0.081-inch (2 mm) thick aluminum, alloy 6063-T5. Blades shall be horizontal, inverted-V type with a center hook and spaced 2-inches (50.8 mm) on center.

STRUCTURAL DESIGN CRITERIA

Manufacturer shall design and furnish all supports required to withstand a wind force of not less than 25 pounds per square foot. Louvers larger than 84-inches (213 cm) wide x 120-inches (305 cm) high or 120-inches (305 cm) wide x 84-inches (213 cm) high will be fabricated and installed in multiple sections. Louver blades, frames, mullions and anchorages shall be demonstrated to withstand the specified wind design load.

PERFORMANCE RATINGS

FREE AREA:	6.80 Square Feet (0.632 m ²)
MINIMUM FREE AREA VELOCITY at Beginning Point of Water Penetration:	1,250 fpm (6.35 m/s)
MINIMUM AIR VOLUME FLOW RATE at Beginning Point of Water Penetration:	8,500 cfm (4.01 m ³ /s)
MAXIMUM STATIC PRESSURE at Beginning Point of Water Penetration:	0.18 in. H ₂ O (0.045 kPa)

See page 3 for Wind-driven Rain Performance
 See page 4 for complete finish options

LOUVER TYPE SCH501 PRODUCT DESCRIPTION & DETAILS

Wind-driven rain is rainfall that is carried by the wind and driven onto the building façade. It is a complex phenomenon of falling raindrops in a turbulent flow of air around a structure. Wind-driven rain is one of the critical factors that ultimately determine the long-term use and effectiveness of building envelopes. In 1999, AMCA Standard 500 was modified to recognize the phenomenon of wind-driven rain with a rigorous new test procedure that measures the effectiveness of louver performance under wind-driven rain conditions. Airolite Storm Class™ louvers are designed and rated to provide high volume intake and exhaust ventilation and prevent water penetration under the most severe wind-driven rain conditions. Airolite Storm Class™ Louver Type SCH501 is a 5-inch (127 mm) deep horizontal blade louver rated to be 99.3% effective at a core ventilation rate of 876 fpm (4.5 m/s) when tested at a wind velocity of 29 mph (13 m/s) and 3-inch (75 mm) per hour rainfall. Airolite Storm Class™ Louver Type SCH501 is a highly effective louver with AMCA Licensed Air Performance, Water Penetration and Wind-driven Rain performance ratings that enable designers to select and specify this product with confidence. Please contact your local Airolite representative or the factory for assistance with the layout and design of support systems when required.

VERTICAL SECTION DETAIL

PLAN SECTION DETAIL

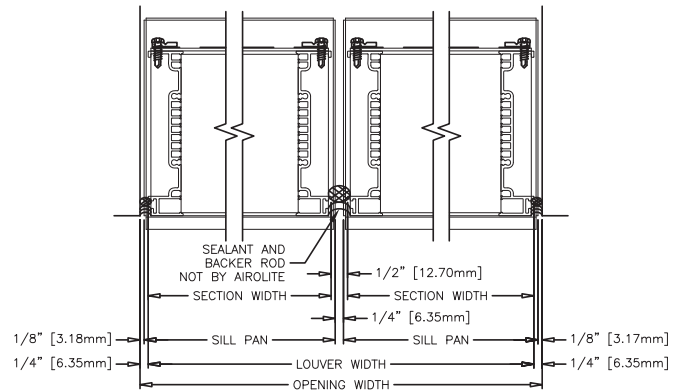
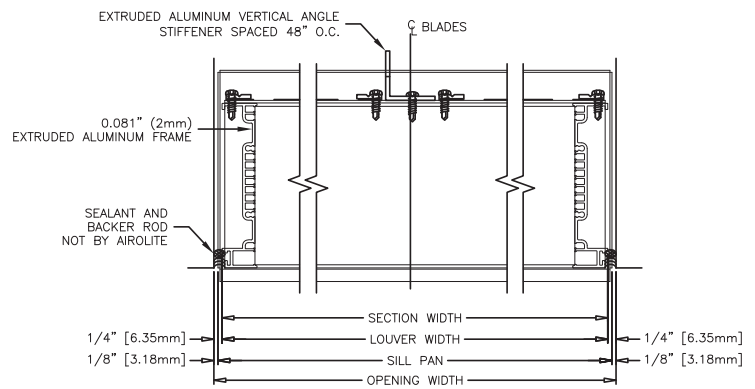
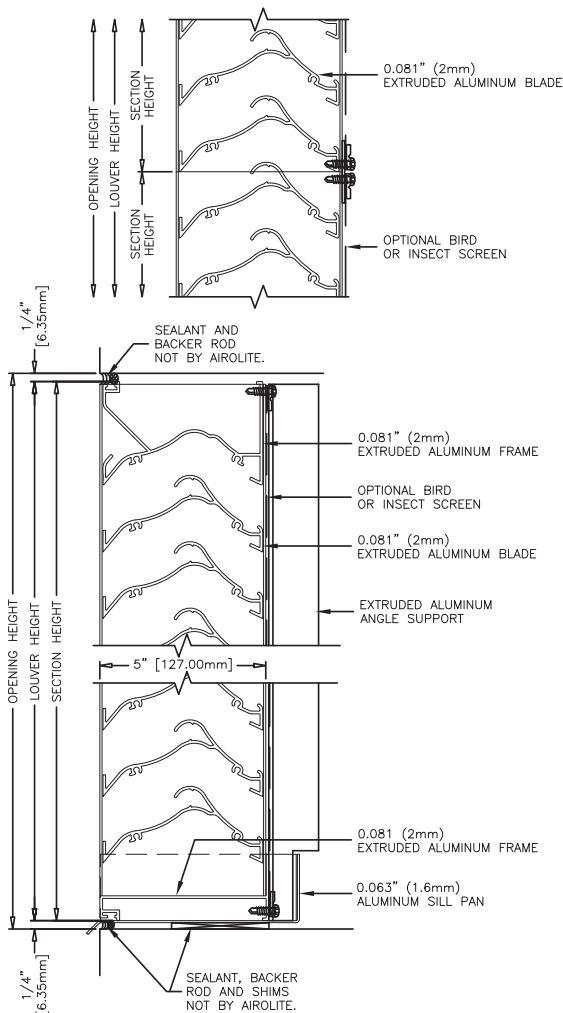

Minimum Section Size:

12 in. (30 cm) W x 7 in. (18 cm) H

Maximum Section Size:

84 in. (213 cm) W x 120 in. (305 cm) H

120 in. (305 cm) W x 84 in. (213 cm) H

LOUVER TYPE SCH501 PERFORMANCE RATINGS

FREE AREA CHART - in square feet

Louver Height Inches	Louver Width in Inches																		
	12	18	24	30	36	42	48	54	60	66	72	78	84	90	96	102	108	114	120
7	0.06	0.11	0.15	0.19	0.23	0.27	0.31	0.34	0.38	0.42	0.46	0.50	0.54	0.58	0.62	0.65	0.69	0.73	0.77
12	0.20	0.33	0.45	0.58	0.71	0.83	0.96	1.05	1.18	1.30	1.43	1.56	1.68	1.81	1.93	2.03	2.16	2.28	2.41
18	0.41	0.66	0.91	1.17	1.42	1.68	1.93	2.12	2.38	2.63	2.89	3.14	3.39	3.65	3.90	4.09	4.35	4.60	4.86
24	0.61	0.99	1.38	1.76	2.14	2.52	2.91	3.19	3.58	3.96	4.34	4.72	5.11	5.49	5.87	6.16	6.54	6.92	7.31
30	0.81	1.33	1.84	2.35	2.86	3.37	3.88	4.26	4.77	5.29	5.80	6.31	6.82	7.33	7.84	8.22	8.73	9.25	9.76
36	1.02	1.66	2.30	2.94	3.58	4.22	4.85	5.33	5.97	6.61	7.25	7.89	8.53	9.17	9.81	10.29	10.93	11.57	12.21
42	1.22	1.99	2.76	3.53	4.29	5.06	5.83	6.40	7.17	7.94	8.71	9.47	10.24	11.01	11.78	12.35	13.12	13.89	14.66
48	1.43	2.32	3.22	4.12	5.01	5.91	6.80	7.47	8.37	9.27	10.16	11.06	11.95	12.85	13.75	14.42	15.31	16.21	17.10
54	1.63	2.66	3.68	4.70	5.73	6.75	7.78	8.54	9.57	10.59	11.62	12.64	13.67	14.69	15.71	16.48	17.51	18.53	19.55
60	1.84	2.99	4.14	5.29	6.45	7.60	8.75	9.62	10.77	11.92	13.07	14.22	15.38	16.53	17.68	18.55	19.70	20.85	22.00
66	2.04	3.32	4.60	5.88	7.16	8.44	9.73	10.69	11.97	13.25	14.53	15.81	17.09	18.37	19.65	20.61	21.89	23.17	24.45
72	2.25	3.65	5.06	6.47	7.88	9.29	10.70	11.76	13.17	14.57	15.98	17.39	18.80	20.21	21.62	22.68	24.08	25.49	26.90
78	2.45	3.99	5.52	7.06	8.60	10.14	11.67	12.83	14.36	15.90	17.44	18.98	20.51	22.05	23.59	24.74	26.28	27.81	29.35
84	2.65	4.32	5.99	7.65	9.32	10.98	12.65	13.90	15.56	17.23	18.89	20.56	22.22	23.89	25.56	26.80	28.47	30.14	31.80
90	2.86	4.65	6.45	8.24	10.03	11.83	13.62	14.97	16.76	18.55	20.35	22.14	23.94	25.73	27.52	28.87	30.66	32.46	34.25
96	3.06	4.99	6.91	8.83	10.75	12.67	14.60	16.04	17.96	19.88	21.80	23.73	25.65	27.57	29.49	30.93	32.86	34.78	36.70
102	3.27	5.32	7.37	9.42	11.47	13.52	15.57	17.11	19.16	21.21	23.26	25.31	27.36	29.41	31.46	33.00	35.05	37.10	39.15
108	3.47	5.65	7.83	10.01	12.19	14.37	16.54	18.18	20.36	22.54	24.71	26.89	29.07	31.25	33.43	35.06	37.24	39.42	41.60
114	3.68	5.98	8.29	10.60	12.90	15.21	17.52	19.25	21.56	23.86	26.17	28.48	30.78	33.09	35.40	37.13	39.43	41.74	44.05
120	3.88	6.32	8.75	11.19	13.62	16.06	18.49	20.32	22.75	25.19	27.63	30.06	32.50	34.93	37.37	39.19	41.63	44.06	46.50

AMCA CERTIFIED RATINGS
WATER PENETRATION
AIR DRIVEN RAIN
PERFORMANCE RATING
INTERNATIONAL, INC.

The Airolite Company, LLC certifies that Louver Type SCH501 shown herein is licensed to bear the AMCA seal. The ratings shown are based on tests and procedures performed in accordance with AMCA Publication 511 and comply with the requirements of the AMCA Certified Ratings Program. The AMCA Certified Ratings Seal applies to Water Penetration, Air Performance and Wind-driven Rain.

WATER PENETRATION

(Standard Air - .075 lb./ft.³)

The AMCA Water Penetration Test provides a method for comparing various louver models and designs as to their efficiency in resisting the penetration of rainfall under specific laboratory test conditions. The beginning point of water penetration is defined as that velocity where the water penetration curve projects through 0.01 oz. of water (penetration) per sq. ft. of louver free area. These performance ratings do not guarantee a louver to be weather-proof or stormproof and should be used in combination with other factors including good engineering judgement in selecting louvers. ***The beginning point of water penetration for Model SCH501 is above 1250 fpm (6.35 m/s) free area velocity.**

WIND-DRIVEN RAIN PERFORMANCE

75mm/h (3 in/hr) Rainfall & 13 m/s (29 mph) Wind Velocity				200mm/h (8 in/hr) Rainfall & 22 m/s (50 mph) Wind Velocity			
Free Area Ventilation Rate (fpm)	Ventilation Air Core Velocity m/s (fpm)	Water Penetration Effect. %	Water Penetration Classification	Free Area Ventilation Rate (fpm)	Ventilation Air Core Velocity m/s (fpm)	Water Penetration Effect. %	Water Penetration Classification
0	0 (0)			0	0 (0)	98.5	B
198	98 (0.5)			278	138 (0.7)	98.1	B
397	197 (1.0)			419	208 (1.1)	97.8	B
595	295 (1.5)			587	291 (1.5)	97.4	B
794	394 (2.0)			837	415 (2.1)	97.8	B
992	492 (2.5)			978	485 (2.5)	98.2	B
1192	591 (3.0)			1185	588 (3.0)	98.4	B
1355	672 (3.4)	99.9	A	1343	666 (3.4)	98.0	B
1585	786 (4.0)	99.5	A	1569	778 (4.0)	97.5	B
1766	876 (4.5)	99.3	A	1766	876 (4.5)	96.4	B
2016	1000 (5.1)	98.7	B	1986	985 (5.0)	93.8	C

Discharge Loss Coefficient Class (Intake) = 3

Weather louvers shall be classified by their ability to reject simulated rain. The table to the left shows different classifications based on the maximum simulated rain penetration per square meter (square feet) of louver. Water penetration rating at a given louver face velocity is determined by the water penetration while the louver is subjected to a selected simulated rainfall rate and wind velocity.



AIRFLOW RESISTANCE

(Standard Air - .075 lb./ft.³)

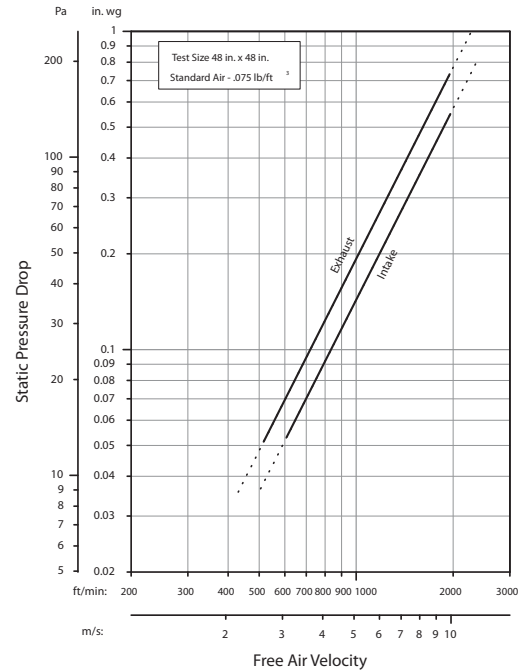

Louver Type SCH501 resistance to airflow varies depending on louver application (air intake or air exhaust). Free area velocities (shown) are higher than the average velocity through the overall louver size.

Discharge Loss Coefficient Classifications	
Class	Discharge Loss Coefficient
1	0.4 and Above
2	0.3 to 0.399
3	0.2 to 0.299
4	0.199 and Below

Wind-driven Rain Penetration Classes	
Class	Effectiveness
A	1 to 0.99
B	0.989 to 0.95
C	0.949 to 0.80
D	Below 0.80

LOUVER TYPE SCH501 METHOD OF INSTALLATION & ACCESSORY OPTIONS

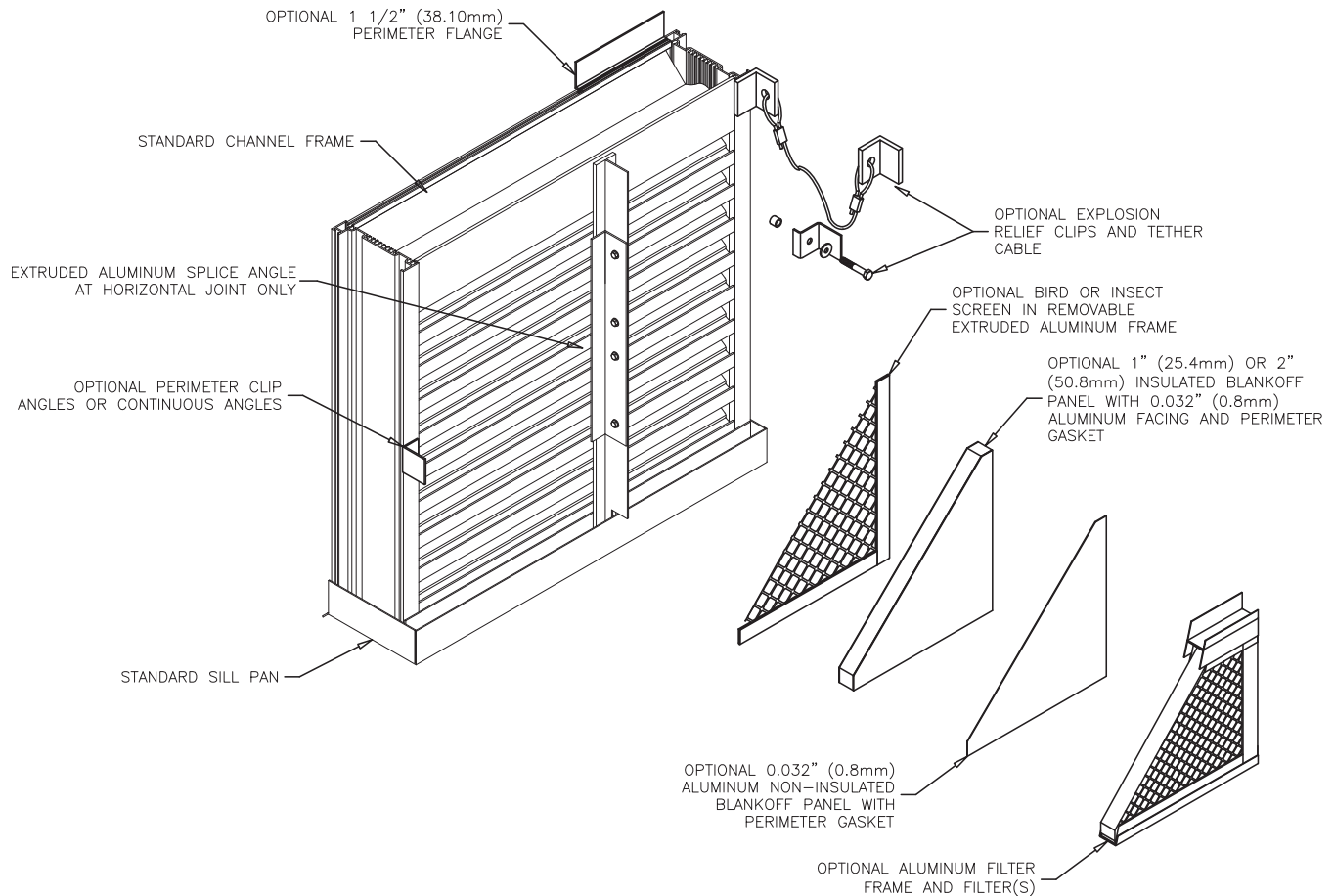

FINISHES (Select one of the following)

ACRYLIC ENAMEL: Louvers shall be cleaned, pretreated and FINISHED-AFTER-ASSEMBLY with an oven-cured thermosetting acrylic enamel finish that meets or exceeds the performance requirements of AAMA 2603, "Voluntary Specification Performance Requirements and Test Procedures for Pigmented Organic Coatings."

2-COAT FLUOROPOLYMER: Louvers shall be cleaned, pretreated and FINISHED-AFTER-ASSEMBLY with an inhibitive primer and oven-cured Kynar 500® / Hylar 5000® resin coating with minimum 1.2 mils dry-film coating thickness that meets or exceeds the performance requirements of AAMA 2605, "Voluntary Specification, Performance Requirements and Test Procedures for Superior Performance Organic Coatings on Aluminum Extrusions and Panels."

3-COAT FLUOROPOLYMER: Louvers shall be cleaned, pretreated and FINISHED-AFTER-ASSEMBLY with an inhibitive primer and oven-cured Kynar 500® / Hylar 5000® resin coating with minimum 2.0 mils dry-film coating thickness that meets or exceeds the performance requirements of AAMA 2605, "Voluntary Specification, Performance Requirements and Test Procedures for Superior Performance Organic Coatings on Aluminum Extrusions and Panels."

CLEAR ANODIZE: Louvers shall be FINISHED-AFTER-ASSEMBLY with a Class I clear anodized coating (AA-M10C22A41) that complies with the performance requirements of AAMA Specification 611-98, "Voluntary Specification for Anodized Architectural Aluminum."

COLOR ANODIZE: Louvers shall be FINISHED-AFTER-ASSEMBLY with a Class I electrolytically color anodized coating (AA-M10C22A42/44) that complies with the performance requirements of AAMA Specification 611-98, "Voluntary Specification for Anodized Architectural Aluminum." Color shall be (select one): Champagne, Light Bronze, Medium Bronze, Dark Bronze, Extra Dark Bronze or Black Anodize.



P.O. Box 410, 525 Western Road, Schofield, WI 54476-0410 USA
715.841.8757 • fax 715.841.8773 • www.airolite.com

Submittal SCH501 June 2010
Copyright ©2010 The Airlite Company, LLC

The Airlite Company, LLC reserves the right to make product changes.