

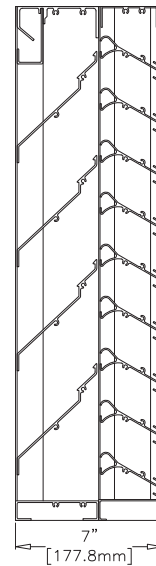

STORM CLASS™ LOUVER

Concealed Mullion Louver Type	SCH7
Material	Extruded Aluminum (Alloy 6063-T5)
Front Blade	0.081 in. (2.06 mm)
Back Blade	0.063 in. (1.60 mm)
Frame	0.081 in. (2.06 mm)
Louver Depth	7 in. (177.8 mm)
Free Area – 4 ft. x 4 ft. Unit	8.07 sq. ft. (0.750 m ²)
Percent Free Area	50.4%
Free Area Velocity at Beginning Point of Water Penetration – 0.01 oz H₂O/sq. ft. Free Area	919 fpm (4.68 m/s)
Air Volume Flow Rate at Beginning Point of Water Penetration – 4 ft. x 4 ft. Unit	7,416 cfm (3.51 m ³ /s)
Pressure Drop at Beginning Point of Water Penetration	0.27 in. H ₂ O (0.055 kPa)
Wind-Driven Rain Water Penetration Data	
Exterior Wind Velocity	29 mph (13 m/s)
Rainfall Rate	3 in. (75 mm)/hour
Effectiveness	99.6%
Core Ventilation Rate	288 fpm (1.5 m/s)



RECOMMENDED SPECIFICATION

GENERAL

Furnish and install where indicated on plans or described in schedules Storm Class™ Louver Type SCH7 as designed and manufactured by The Airlite Company LLC, Schofield, Wisconsin. Louvers shall be furnished with bird screen, insect screen, supports, installation hardware and finishes as specified and as required for a complete installation.

SUBMITTALS

Manufacturer shall submit shop drawings incorporating key plans, elevations, sections and details showing profiles, angles and spacing of louver blades and frames; unit dimensions related to wall openings and construction; and, anchorage details and locations. Submit theoretical calculations prepared by a professional engineer specializing in the application of welding technology demonstrating that each fillet weld joining blade and frame members will withstand a minimum of 526 pounds of force in shear. Provide samples of manufacturer's finish and color charts showing the full range of colors available. For each type of product specified, submit free area, air performance, water penetration and wind-driven rain ratings determined in accordance with AMCA Standard 500-L 99 and licensed under the AMCA Certified Ratings Program.

PRODUCTS

Louvers shall be Storm Class™ type and rated to resist water penetration under wind-driven rain conditions. Louvers shall be 7-inches (177.8 mm) deep and assembled entirely from extruded aluminum components. Exterior blades and frames shall be 0.081-inch (2 mm) thick extruded aluminum, alloy 6063-T5. Interior blades shall be 0.063-inch (1.6 mm) extruded aluminum, alloy 6063-T5. Exterior blades shall be horizontal and spaced 5-inches (127.0 mm) on center.

ALL-WELDED ASSEMBLY

Join stationary blade and frames and frame members with fillet welds concealed from view, unless the size of the louver makes bolted connections between louver sections necessary. Louver blades shall be joined to each jamb frame with a minimum of two fillet welds produced with the Pulsed Gas Metal Arc Welding (GMAW/Mig) process. Each weld shall be a minimum of 1-inch (25.4 mm) in length with a minimum 1/8-inch (3.175 mm) leg. Frames shall be joined at each corner with a full-length GMAW fillet weld with a minimum 1/8-inch (3.175 mm) throat.

STRUCTURAL DESIGN CRITERIA

Manufacturer shall design and furnish all supports required to withstand a wind force of not less than 25 pounds per square foot. Louvers larger than 144-inches wide x 72-inches high or 72-inches wide x 144-inches high will be fabricated and installed in multiple sections. Louver blades, frames, mullions and anchorages shall be demonstrated to withstand the specified wind design load.

PERFORMANCE RATINGS

FREE AREA:	8.07 Square Feet (0.750 m ²)
MINIMUM FREE AREA VELOCITY at Beginning Point of Water Penetration:	919 fpm (4.68 m/s)
MINIMUM AIR VOLUME FLOW RATE at Beginning Point of Water Penetration:	7,416 cfm (3.51 m ³ /s)
MAXIMUM STATIC PRESSURE at Beginning Point of Water Penetration:	0.27 in. H ₂ O (0.055 kPa)

See page 3 for complete Wind-driven Rain Performance
See page 4 for complete finish options

LOUVER TYPE SCH7 PERFORMANCE RATINGS

FREE AREA CHART - in square feet

Louver Height Inches	Louver Width in Inches											
	12	24	36	48	60	72	84	96	108	120	132	144
12	0.18	0.44	0.70	0.96	1.22	1.48	1.74	2.00	2.26	2.52	2.78	3.03
24	0.64	1.55	2.46	3.36	4.27	5.18	6.09	6.99	7.90	8.81	9.71	10.62
36	1.10	2.66	4.21	5.77	7.32	8.88	10.43	11.99	13.54	15.10	16.65	18.21
48	1.54	3.72	5.90	8.07	10.25	12.43	14.61	16.78	18.96	21.14	23.32	25.49
60	1.93	4.65	7.37	10.09	12.81	15.53	18.26	20.98	23.70	26.42	29.14	31.86
72	2.39	5.76	9.12	12.49	15.86	19.23	22.60	25.97	29.34	32.71	36.08	39.45
84	2.85	6.86	10.88	14.90	18.91	22.93						
96	3.38	8.15	12.92	17.69	22.45	27.22						
108	3.76	9.08	14.39	19.70	25.01	30.33						
120	4.13	9.96	15.79	21.62	27.46	33.29						
132	4.59	11.07	17.55	24.03	30.51	36.99						
144	5.05	12.18	19.30	26.43	33.56	40.68						



The Airlite Company, LLC certifies that Louver Type SCH7 shown herein is licensed to bear the AMCA seal. The ratings shown are based on tests and procedures performed in accordance with AMCA Publication 511 and comply with the requirements of the AMCA Certified Ratings Program. The AMCA Certified Ratings Seal applies to Water Penetration, Air Performance and Wind-driven Rain.

WATER PENETRATION

(Standard Air - .075 lb./ft.³; Test Size - 48 in. x 48 in.; Test Duration - 15 min.)

The AMCA Water Penetration Test provides a method for comparing various louver models and designs as to their efficiency in resisting the penetration of rainfall under specific laboratory test conditions. The beginning point of water penetration is defined as that velocity where the water penetration curve projects through 0.01 oz. of water (penetration) per sq. ft. of louver free area. These performance ratings do not guarantee a louver to be weather-proof or stormproof and should be used in combination with other factors including good engineering judgement in selecting louvers. ***The beginning point of water penetration for Model SCH7 is 919 fpm (4.68 m/s) free area velocity.**

WIND-DRIVEN RAIN PERFORMANCE

Free Area Ventilation Rate (fpm)	Ventilation Air Core Velocity m/s (fpm)	75mm/h (3 in/hr) Rainfall & 13 m/s (29 mph) Wind Velocity		200mm/h (8 in/hr) Rainfall & 22 m/s (50 mph) Wind Velocity	
		Water Penetration Effectiveness	Water Penetration Classification	Water Penetration Effectiveness	Water Penetration Classification
		%		%	
0	0.0 (0)	99.9	A	N/A	N/A
179	0.5 (98)	99.9	A	N/A	N/A
370	1.0 (197)	99.9	A	N/A	N/A
511	1.5 (295)	99.6	A	N/A	N/A
672	2.0 (394)	98.7	B	N/A	N/A
850	2.5 (492)	93.5	C	N/A	N/A
1,043	3.0 (591)	72.2	D	N/A	N/A
1,211	3.5 (689)	44.8	D	N/A	N/A

Discharge Loss Coefficient Class (Intake) = 3

Weather louvers shall be classified by their ability to reject simulated rain. The table to the right shows different classifications based on the maximum simulated rain penetration per square meter (square feet) of louver. Water penetration rating at a given louver face velocity is determined by the water penetration while the louver is subjected to a selected simulated rainfall rate and wind velocity.

Discharge Loss Coefficient Classifications	
Class	Discharge Loss Coefficient
1	0.4 and Above
2	0.3 to 0.399
3	0.2 to 0.299
4	0.199 and Below

Wind-driven Rain Penetration Classes	
Class	Effectiveness
A	1 to 0.99
B	0.989 to 0.95
C	0.949 to 0.80
D	Below 0.80

AIRFLOW RESISTANCE

(Standard Air - .075 lb./ft.³)

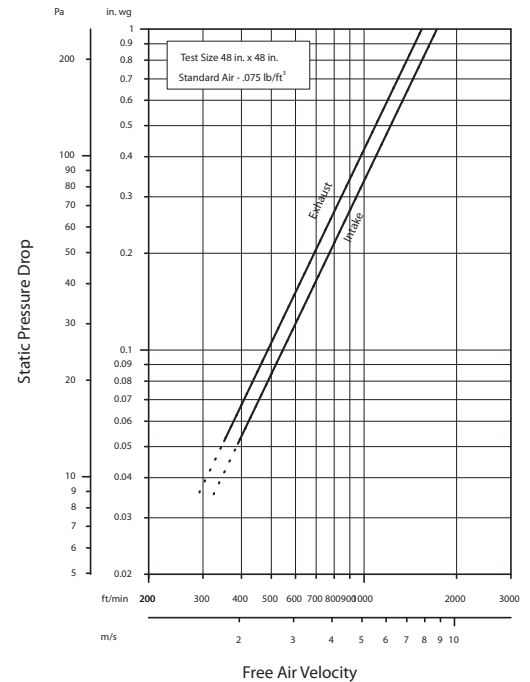

Louver Type SCH7 resistance to airflow varies depending on louver application (air intake or air exhaust). Free area velocities (shown) are higher than the average velocity through the overall louver size.

LOUVER TYPE SCH7 METHOD OF INSTALLATION & ACCESSORY OPTIONS

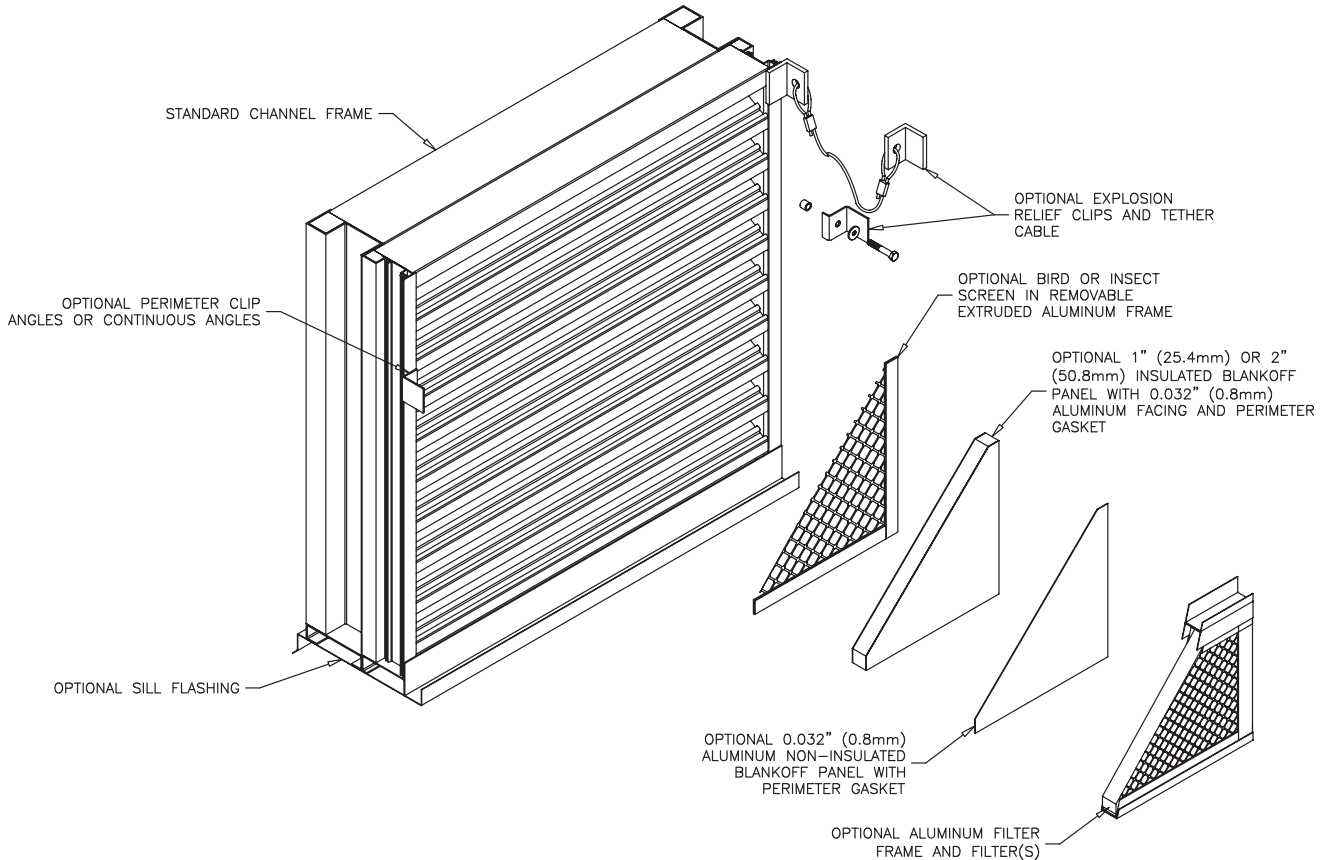

FINISHES* (Select one of the following)

ACRYLIC ENAMEL: Louvers shall be cleaned, pretreated and Finished with an oven-cured thermosetting acrylic enamel finish that meets or exceeds the performance requirements of AAMA 2603, "Voluntary Specification Performance Requirements and Test Procedures for Pigmented Organic Coatings."

2-COAT FLUOROPOLYMER: Louvers shall be cleaned, pretreated and Finished with an inhibitive primer and oven-cured Kynar 500® / Hylar 5000® resin coating with minimum 1.2 mils dry-film coating thickness that meets or exceeds the performance requirements of AAMA 2605, "Voluntary Specification, Performance Requirements and Test Procedures for Superior Performance Organic Coatings on Aluminum Extrusions and Panels."

3-COAT FLUOROPOLYMER: Louvers shall be cleaned, pretreated and Finished with an inhibitive primer and oven-cured Kynar 500® / Hylar 5000® resin coating with minimum 2.0 mils dry-film coating thickness that meets or exceeds the performance requirements of AAMA 2605, "Voluntary Specification, Performance Requirements and Test Procedures for Superior Performance Organic Coatings on Aluminum Extrusions and Panels."

CLEAR ANODIZE: Louvers shall be Finished with a Class I clear anodized coating (AA-M10C22A41) that complies with the performance requirements of AAMA Specification 611-98, "Voluntary Specification for Anodized Architectural Aluminum."

COLOR ANODIZE: Louvers shall be Finished with a Class I electrolytically color anodized coating (AA-M10C22A42/44) that complies with the performance requirements of AAMA Specification 611-98, "Voluntary Specification for Anodized Architectural Aluminum." Color shall be (select one): Champagne, Light Bronze, Medium Bronze, Dark Bronze, Extra Dark Bronze or Black Anodize.

* Finish applied to exterior louver module only. Specify finish applied to interior louver module when required.



P.O. Box 410, 525 Western Road, Schofield, WI 54476-0410 USA
715.841.8757 • fax 715.841.8773 • www.airolite.com

Submittal SCH7 May 2006, Revision 5
Copyright ©2006 The Airlite Company, LLC

The Airlite Company, LLC reserves the right to make product changes.

THE ALL-WELDED ADVANTAGE 